



ENGINEERED FOR ENDURANCE



| | |
|-----------------------------------|------------|
| VERTICAL STORAGE TANKS | 10 |
| HORIZONTAL TRANSPORT TANKS | 24 |
| NURSE TRAILERS | 38 |
| CONE BOTTOM TRAILERS | 54 |
| CHEMICAL HANDLING SYSTEM | 60 |
| SPRAY EQUIPMENT | 70 |
| FIRE EQUIPMENT | 90 |
| REFUELING EQUIPMENT | 108 |

IMPROVING FAMILY FARM OPERATIONS™

Your operation is only as good as the equipment you choose to trust, which isn't a responsibility we take lightly. Every one of our products takes longer to design and costs more to craft. We overbuild, torture test, and back them with the longest warranty in the industry.

We were the first in the USA to use a Pin-Mount™ system to attach transport tanks to trailers, making them safer and easier to maintain. We build our liquid storage tanks with ribbed walls, a stronger roof, and 30% stronger raw materials to safeguard your liquids investment. We pioneered the counter-balanced tractor sprayer tank to reduce tractor rollovers, the No. 1 on-the-job killer of farmers.

If we can't build something that makes farming safer, more efficient, or more reliable, we don't build it. And we proudly manufacture every tank here in the USA, where we can personally make sure every product that leaves our doors is strong enough to carry the weight of your harvest.

20 YEARS STRONG: POWERING AGRICULTURAL INNOVATION

When we first started, our goal was simple: to create the most durable and reliable sprayers, water tanks, and chemical transport on the market. We knew that people needed equipment that could withstand harsh conditions and last for years to come, so we set out to make that a reality.

We started small, with just a handful of employees and a few basic machines. But as word spread about our products, our business grew. We invested in new technologies and expanded our product line to meet the evolving needs of farmers across the nation.

Today, we're proud to say that we offer a wide range of equipment, from liquid storage and sprayers to refueling equipment and the toughest water tanks on the market. Our products are used by farmers nationwide, from small family farms to large-scale operations.

But even as we've grown and evolved over the years, our commitment to quality and durability has never wavered.

We know that our customers rely on our equipment to get their work done, and we take that responsibility seriously. That's why we use only the highest-quality materials in our products and why we put them through rigorous testing to ensure they can withstand the toughest conditions.

Looking back on the past 20 years, we're grateful for everyone who has been a part of our journey. We're excited to continue pushing the boundaries of what's possible in agricultural equipment. We're committed to staying at the forefront of innovation and to providing our customers with the best possible products and services.

Thank you for joining us on this journey. Here's to the next 20 years.

TEAM ENDURAPLAS



INDUSTRY-LEADING EQUIPMENT WITH A LOCAL TOUCH

When you buy from one of our dealers, you're getting more than just our products. You're getting a team of experts who will work with you to find the perfect solution for your specific needs. We work tirelessly to ensure that our products are the best in the market, and we only partner with dealers who share our commitment to excellence. Our dealers understand the hard work that goes into the agriculture industry and are always ready to roll up their sleeves and get to work. They know the challenges that farmers face and are always willing to go the extra mile to ensure your satisfaction.



TANKS



THV SERIES

FLAT BOTTOM STORAGE TANK



TEAL



BLACK



THE ULTIMATE LIQUIDS PROTECTION

We overbuild these tanks from every angle with thicker walls, a reinforced Strong-X™ roof design, and built-in ribs to prevent the walls from bowing when the loads get heavy. This tank is so tough that it still held liquid after we dropped a Chevy Blazer on it in our torture test.

STRONG-X™ ROOF DESIGN

The beefed up roof structure with molded-in truss-like supports will not collapse in extreme weather conditions.

RIBBED-WALL™ STRUCTURE

The ribs act like belts around the tank, keeping it in shape - this reduces bulging.

THICK-WALL™ DESIGN

Extra-thick walls provide unmatched strength and durability.

ANCHOR-POINT™ LUGS

Four hefty built-in lifting and tie-down points at each corner make it easy to handle.



ROTO-MOLD CONSTRUCTION



When cooked and cooled at an even rate, the raw material is bonded together to make this tank virtually indestructible.



SINGLE-PIECE™ CONSTRUCTION



Rotationally-molded in a single mold means the tank is seamless, water-tight and leak-proof.

SPECIFICATIONS

| THV10000 | | THV06250 | | THV06000 | |
|------------------|---|------------------|---|------------------|---|
| TANK GALLON SIZE | 10,400 | TANK GALLON SIZE | 6,300 | TANK GALLON SIZE | 6,500 |
| DIAMETER | 144" | DIAMETER | 120" | DIAMETER | 110" |
| HEIGHT | 178" | HEIGHT | 147" | HEIGHT | 179" |
| LID SIZE | 16" | LID SIZE | 16" | LID SIZE | 16" |
| FITTING SIZE | 3" | FITTING SIZE | 3" | FITTING SIZE | 3" |
| SPECIFIC GRAVITY | 1.9 | SPECIFIC GRAVITY | 1.9 | SPECIFIC GRAVITY | 1.9 |
| SIPHON TUBE | ✓ | SIPHON TUBE | ✓ | SIPHON TUBE | ✓ |
| COLORS* | TEAL, BLACK | COLORS* | TEAL, BLACK | COLORS* | TEAL, BLACK |
| MANUFACTURED IN |  | MANUFACTURED IN |  | MANUFACTURED IN |  |

| THV05200 | | THV05000 | | THV03000 | |
|------------------|---|------------------|---|------------------|---|
| TANK GALLON SIZE | 5,200 | TANK GALLON SIZE | 5,500 | TANK GALLON SIZE | 3,126 |
| DIAMETER | 100" | DIAMETER | 110" | DIAMETER | 90" |
| HEIGHT | 164" | HEIGHT | 150" | HEIGHT | 125" |
| LID SIZE | 16" | LID SIZE | 16" | LID SIZE | 16" |
| FITTING SIZE | 3" | FITTING SIZE | 3" | FITTING SIZE | 3" |
| SPECIFIC GRAVITY | 1.9 | SPECIFIC GRAVITY | 1.9 | SPECIFIC GRAVITY | 1.9 |
| SIPHON TUBE | ✓ | SIPHON TUBE | ✓ | SIPHON TUBE | ✓ |
| COLORS* | TEAL, BLACK | COLORS* | TEAL, BLACK | COLORS* | TEAL, BLACK |
| MANUFACTURED IN |  | MANUFACTURED IN |  | MANUFACTURED IN |  |

| THV02500 | | THV01750 | | THV01550 | |
|------------------|---|------------------|---|------------------|---|
| TANK GALLON SIZE | 2,680 | TANK GALLON SIZE | 2,009 | TANK GALLON SIZE | 1,700 |
| DIAMETER | 90" | DIAMETER | 85" | DIAMETER | 85" |
| HEIGHT | 113" | HEIGHT | 89" | HEIGHT | 80" |
| LID SIZE | 16" | LID SIZE | 16" | LID SIZE | 16" |
| FITTING SIZE | 2" | FITTING SIZE | 2" | FITTING SIZE | 2" |
| SPECIFIC GRAVITY | 1.9 | SPECIFIC GRAVITY | 1.9 | SPECIFIC GRAVITY | 1.9 |
| SIPHON TUBE | ✗ | SIPHON TUBE | ✗ | SIPHON TUBE | ✗ |
| COLORS* | TEAL, BLACK | COLORS* | TEAL, BLACK | COLORS* | TEAL, BLACK |
| MANUFACTURED IN |  | MANUFACTURED IN |  | MANUFACTURED IN |  |

| THV01125 | | THV01100 | | THV00550 | |
|------------------|---|------------------|---|------------------|---|
| TANK GALLON SIZE | 1,125 | TANK GALLON SIZE | 1,100 | TANK GALLON SIZE | 550 |
| DIAMETER | 85" | DIAMETER | 60" | DIAMETER | 60" |
| HEIGHT | 56" | HEIGHT | 97" | HEIGHT | 52" |
| LID SIZE | 16" | LID SIZE | 16" | LID SIZE | 16" |
| FITTING SIZE | 2" | FITTING SIZE | 2" | FITTING SIZE | 2" |
| SPECIFIC GRAVITY | 1.9 | SPECIFIC GRAVITY | 1.9 | SPECIFIC GRAVITY | 1.9 |
| SIPHON TUBE | ✗ | SIPHON TUBE | ✗ | SIPHON TUBE | ✗ |
| COLORS* | TEAL, BLACK | COLORS* | TEAL, BLACK | COLORS* | TEAL, BLACK |
| MANUFACTURED IN |  | MANUFACTURED IN |  | MANUFACTURED IN |  |

*Yellow & White are available upon special request.



**FAST, RESPONSIVE
CUSTOMER SUPPORT**



MADE IN USA



**ONLINE PARTS
STORE**



**LEAK-PROOF
DESIGN**



**LONGEST WARRANTY
IN THE INDUSTRY**



**DESIGNED FOR
SAFETY**



**SUPPORTIVE DEALER
NETWORK**



**TESTED FOR
TOUGHNESS**



**ROTOMOLDED USING
HIGH-QUALITY MATERIAL**

THE HEAVIEST TANK IN AMERICA

Your storage tanks have a lot riding on them. Spilled liquid could be an unexpected expense at best and irreplaceable come spray season at worst. Our engineers developed every element of our flat bottom and cone bottom tanks to give you the safest, heaviest, and most durable liquid storage option you can buy. Our tank walls are thicker and our Ribbed-Wall™ design prevents the walls from flexing under heavy loads. Our Strong-X™ roof design prevents the roof from collapsing. We even manufacture our polymer using a more expensive high-pressure extrusion process to make our raw material 30% stronger than the competition's dry mix polymer.

THC SERIES

CONE BOTTOM STORAGE TANK



TEAL



BLACK



FULLY-DRAINING LIQUID STORAGE

This fully-draining version of our storage tank includes a 15° cone-shaped bottom, making it easy to use for different liquids throughout the year.

STRONG-X™ ROOF DESIGN

The beefed up roof structure with molded-in truss-like supports will not collapse in extreme weather conditions.

RIBBED-WALL™ STRUCTURE

The ribs act like belts around the tank, keeping it in shape - this reduces bulging.

THICK-WALL™ DESIGN

Extra-thick walls provide unmatched strength and durability.

ANCHOR-POINT™ LUGS

Four hefty built-in lifting and tie-down points at each corner make it easy to handle.

AUTO-DRAIN™ CONE BASE

The 15° cone base channels every ounce of liquid to the drain.

SINGLE-PIECE™ CONSTRUCTION

Rotationally-molded in a single mold means the tank is seamless, water-tight and leak-proof.

SPECIFICATIONS

| THC10000K | | THC05000K | |
|------------------|-------------|------------------|-------------|
| TANK GALLON SIZE | 10,400 | TANK GALLON SIZE | 5,500 |
| STAND INCLUDED | ✓ | STAND INCLUDED | ✓ |
| DIAMETER | 144" | DIAMETER | 110" |
| HEIGHT | 202" | HEIGHT | 175" |
| LID SIZE | 16" | LID SIZE | 16" |
| FITTING SIZE | 3" | FITTING SIZE | 3" |
| SPECIFIC GRAVITY | 1.9 | SPECIFIC GRAVITY | 1.9 |
| SIPHON TUBE | ✓ | SIPHON TUBE | ✓ |
| COLORS* | TEAL, BLACK | COLORS* | TEAL, BLACK |
| MANUFACTURED IN | TX ND | MANUFACTURED IN | ND |

| THC03000K | | THC01550K | |
|------------------|-------------|------------------|-------------|
| TANK GALLON SIZE | 3,126 | TANK GALLON SIZE | 1,700 |
| STAND INCLUDED | ✓ | STAND INCLUDED | ✓ |
| DIAMETER | 90" | DIAMETER | 85" |
| HEIGHT | 146" | HEIGHT | 87" |
| LID SIZE | 16" | LID SIZE | 16" |
| FITTING SIZE | 3" | FITTING SIZE | 2" |
| SPECIFIC GRAVITY | 1.9 | SPECIFIC GRAVITY | 1.9 |
| SIPHON TUBE | ✓ | SIPHON TUBE | ✓ |
| COLORS* | TEAL, BLACK | COLORS* | TEAL, BLACK |
| MANUFACTURED IN | TX ND | MANUFACTURED IN | ND |

| THC10000 | | THC05000 | |
|------------------|-------------|------------------|-------------|
| TANK GALLON SIZE | 10,400 | TANK GALLON SIZE | 5,500 |
| STAND INCLUDED | ✗ | STAND INCLUDED | ✗ |
| DIAMETER | 144" | DIAMETER | 110" |
| HEIGHT | 193" | HEIGHT | 166" |
| LID SIZE | 16" | LID SIZE | 16" |
| FITTING SIZE | 3" | FITTING SIZE | 3" |
| SPECIFIC GRAVITY | 1.9 | SPECIFIC GRAVITY | 1.9 |
| SIPHON TUBE | ✓ | SIPHON TUBE | ✓ |
| COLORS* | TEAL, BLACK | COLORS* | TEAL, BLACK |
| MANUFACTURED IN | TX ND | MANUFACTURED IN | ND |

| THC03000 | | THC01550 | |
|------------------|-------------|------------------|-------------|
| TANK GALLON SIZE | 3,126 | TANK GALLON SIZE | 1,700 |
| STAND INCLUDED | ✗ | STAND INCLUDED | ✗ |
| DIAMETER | 90" | DIAMETER | 85" |
| HEIGHT | 136" | HEIGHT | 77" |
| LID SIZE | 16" | LID SIZE | 16" |
| FITTING SIZE | 3" | FITTING SIZE | 2" |
| SPECIFIC GRAVITY | 1.9 | SPECIFIC GRAVITY | 1.9 |
| SIPHON TUBE | ✓ | SIPHON TUBE | ✓ |
| COLORS* | TEAL, BLACK | COLORS* | TEAL, BLACK |
| MANUFACTURED IN | TX ND | MANUFACTURED IN | ND |

*Yellow & White are available upon special request.



**FAST, RESPONSIVE
CUSTOMER SUPPORT**



MADE IN USA



**ONLINE PARTS
STORE**



**LEAK-PROOF
DESIGN**



**LONGEST WARRANTY
IN THE INDUSTRY**



**DESIGNED FOR
SAFETY**



**SUPPORTIVE DEALER
NETWORK**



**TESTED FOR
TOUGHNESS**



**ROTOMOLDED USING
HIGH-QUALITY MATERIAL**



COMPOUND-COLOR™ POLYMER

Simply pouring colored powder into the mix may be the easy way to create roto molded polymer... but easy isn't how we do things. Our raw material is forged using a high-pressure extrusion process that forces the color into the polymer at a molecular level. With additional secret ingredients, the result is 30% stronger and it enables us to produce our line of completely light-blocking sprayer tanks that eliminate algae growth.

THE SERIES

FREESTANDING TRANSPORT TANK



TEAL



BLACK



TOUGH LIQUID STORAGE ON THE GO

Taking your liquids on the road puts extreme forces on your tank... we've packed our transport tanks with features. From our Pin-Mount™ System to available Anti-Splash™ stainless lids, these enhancements minimize the risk of losing your valuable liquids investment to the pavement.

LIFTING-LUGS™

Built-in and engineered to take the weight of the tank, these make lifting the tank on and off the trailer a breeze.*

*Dry Weight Only.

PIN-MOUNT™ SYSTEM

The molded-in mounting lugs combined with heavy-duty steel pins will keep this tank fixed without movement.

THICK-WALL™ DESIGN

Extra-thick walls provide unmatched strength and durability.

ANTI-SPLASH™ STAINLESS LID

Lockable and spill-proof, this lid keeps liquid in while traveling on rough terrain.*

*Only on tanks 1,600 gallons or larger.

ROTO-MOLD CONSTRUCTION

When cooked and cooled at an even rate, the raw material is bonded together to make this tank virtually indestructible.



SINGLE-PIECE™ CONSTRUCTION



Rotationally-molded in a single mold means the tank is seamless, water-tight and leak-proof.

SPECIFICATIONS

| THF04500 | | NEW THF03600 | | THF03200 | |
|--------------------|---|---------------------|---|--------------------|---|
| TANK GALLON SIZE | 4,500 | TANK GALLON SIZE | 3,600 | TANK GALLON SIZE | 3,200 |
| DIMENSIONS (LxWxH) | 180" x 95" x 90" | DIMENSIONS (LxWxH) | 144" x 96" x 95" | DIMENSIONS (LxWxH) | 144" x 96" x 83" |
| LID SIZE | 16" | LID SIZE | 16" | LID SIZE | 16" |
| LID TYPE | STAINLESS STEEL | LID TYPE | STAINLESS STEEL | LID TYPE | STAINLESS STEEL |
| FITTING SIZE | 3" | FITTING SIZE | 3" | FITTING SIZE | 3" |
| SPECIFIC GRAVITY | 1.9 | SPECIFIC GRAVITY | 1.9 | SPECIFIC GRAVITY | 1.9 |
| COLORS* | TEAL, BLACK | COLORS* | TEAL, BLACK | COLORS* | TEAL, BLACK |
| MANUFACTURED IN |  | MANUFACTURED IN |  | MANUFACTURED IN |  |

| THF02800 | | NEW THF02400 | | THF02200 | |
|--------------------|---|---------------------|---|--------------------|---|
| TANK GALLON SIZE | 2,800 | TANK GALLON SIZE | 2,400 | TANK GALLON SIZE | 2,200 |
| DIMENSIONS (LxWxH) | 144" x 96" x 75" | DIMENSIONS (LxWxH) | 149" x 96" x 67" | DIMENSIONS (LxWxH) | 131" x 71" x 79" |
| LID SIZE | 16" | LID SIZE | 16" | LID SIZE | 16" |
| LID TYPE | STAINLESS STEEL | LID TYPE | STAINLESS STEEL | LID TYPE | STAINLESS STEEL |
| FITTING SIZE | 3" | FITTING SIZE | 3" | FITTING SIZE | 3" |
| SPECIFIC GRAVITY | 1.9 | SPECIFIC GRAVITY | 1.9 | SPECIFIC GRAVITY | 1.9 |
| COLORS* | TEAL, BLACK | COLORS* | TEAL, BLACK | COLORS* | TEAL, BLACK |
| MANUFACTURED IN |  | MANUFACTURED IN |  | MANUFACTURED IN |  |

| THF01900 | | THF01600 | | THF01200 | |
|--------------------|---|--------------------|---|--------------------|---|
| TANK GALLON SIZE | 1,900 | TANK GALLON SIZE | 1,600 | TANK GALLON SIZE | 1,200 |
| DIMENSIONS (LxWxH) | 131" x 71" x 70" | DIMENSIONS (LxWxH) | 131" x 71" x 60" | DIMENSIONS (LxWxH) | 103" x 71" x 60" |
| LID SIZE | 16" | LID SIZE | 16" | LID SIZE | 16" |
| LID TYPE | STAINLESS STEEL | LID TYPE | STAINLESS STEEL | LID TYPE | STAINLESS STEEL |
| FITTING SIZE | 3" | FITTING SIZE | 3" | FITTING SIZE | 2" |
| SPECIFIC GRAVITY | 1.9 | SPECIFIC GRAVITY | 1.9 | SPECIFIC GRAVITY | 1.9 |
| COLORS* | TEAL, BLACK | COLORS* | TEAL, BLACK | COLORS* | TEAL, BLACK |
| MANUFACTURED IN |  | MANUFACTURED IN |  | MANUFACTURED IN |  |

| THF01000 | | THF00500 | | THF00400 | |
|--------------------|---|--------------------|---|--------------------|---|
| TANK GALLON SIZE | 1,100 | TANK GALLON SIZE | 550 | TANK GALLON SIZE | 400 |
| DIMENSIONS (LxWxH) | 95" x 60" x 63" | DIMENSIONS (LxWxH) | 80" x 57" x 44" | DIMENSIONS (LxWxH) | 79" x 46" x 39" |
| LID SIZE | 16" | LID SIZE | 16" | LID SIZE | 16" |
| LID TYPE | STAINLESS STEEL | LID TYPE | STAINLESS STEEL | LID TYPE | STAINLESS STEEL |
| FITTING SIZE | 2" | FITTING SIZE | 2" | FITTING SIZE | 2" |
| SPECIFIC GRAVITY | 1.9 | SPECIFIC GRAVITY | 1.9 | SPECIFIC GRAVITY | 1.9 |
| COLORS* | TEAL, BLACK | COLORS* | TEAL, BLACK | COLORS* | TEAL, BLACK |
| MANUFACTURED IN |  | MANUFACTURED IN |  | MANUFACTURED IN |  |

| THF00250 | | MOUNTING PINS | |
|--------------------|---|----------------------|-------------|
| TANK GALLON SIZE | 260 | TANK GALLON SIZE | PINS NEEDED |
| DIMENSIONS (LxWxH) | 56" x 48" x 34" | 4,500 - 1,600 | 8 x AZP04 |
| LID SIZE | 16" | 1,200 | 6 x AZP04 |
| LID TYPE | STAINLESS STEEL | 1,000 - 500 | 6 x AZP03 |
| FITTING SIZE | 2" | 400 | 4 x AZP02 |
| SPECIFIC GRAVITY | 1.9 | 250 | 4 x AZP01 |
| COLORS* | TEAL, BLACK | | |
| MANUFACTURED IN |  | | |

*Yellow & White are available upon special request.



**FAST, RESPONSIVE
CUSTOMER SUPPORT**



MADE IN USA



**ONLINE PARTS
STORE**



**LEAK-PROOF
DESIGN**



**LONGEST WARRANTY
IN THE INDUSTRY**



**DESIGNED FOR
SAFETY**



**SUPPORTIVE DEALER
NETWORK**



**TESTED FOR
TOUGHNESS**



**ROTOMOLDED USING
HIGH-QUALITY MATERIAL**

THD SERIES

SUMP BOTTOM TRANSPORT TANK



TEAL



BLACK



LEAVE NOTHING IN THE TANK

Our sump bottom transport tank gives you our premium features: pin-mounts, thick walls, and available stainless lids. The fully-draining sump bottom prevents liquid from staying at the base of the tank.



LIFTING-LUGS™

Built-in and engineered to take the weight of the tank, these make lifting the tank on and off the trailer a breeze.

*Dry Weight Only.

PIN-MOUNT™ SYSTEM

The molded-in mounting lugs combined with heavy-duty steel pins will keep this tank fixed without movement.

THICK-WALL™ DESIGN

Extra-thick walls provide unmatched strength and durability.

ANTI-SPLASH™ STAINLESS LID

Lockable and spill-proof, this lid keeps liquid in while traveling on rough terrain.

*Only on tanks 1,600 gallons or larger.

AUTO-DRAIN™ SUMP BASE

The sloped tank base channels every ounce of liquid to the drain.

SINGLE-PIECE™ CONSTRUCTION

Rotationally-molded in a single mold means the tank is seamless, water-tight and leak-proof.

| NEW THD03600K | | THD03200K | | THD02800K | |
|------------------------|-------------------|------------------------|------------------|------------------------|------------------|
| TANK GALLON SIZE | 3,600 | TANK GALLON SIZE | 3,200 | TANK GALLON SIZE | 2,800 |
| FRAME | ✓ | FRAME | ✓ | FRAME | ✓ |
| MOUNTING PINS INCLUDED | ✓ | MOUNTING PINS INCLUDED | ✓ | MOUNTING PINS INCLUDED | ✓ |
| DIMENSIONS (LxWxH) | 145" x 96" x 101" | DIMENSIONS (LxWxH) | 145" x 96" x 88" | DIMENSIONS (LxWxH) | 145" x 96" x 80" |
| LID SIZE | 16" | LID SIZE | 16" | LID SIZE | 16" |
| LID TYPE | STAINLESS STEEL | LID TYPE | STAINLESS STEEL | LID TYPE | STAINLESS STEEL |
| SPECIFIC GRAVITY | 1.9 | SPECIFIC GRAVITY | 1.9 | SPECIFIC GRAVITY | 1.9 |
| COLORS* | TEAL, BLACK | COLORS* | TEAL, BLACK | COLORS* | TEAL, BLACK |
| MANUFACTURED IN | ND | MANUFACTURED IN | TX ND | MANUFACTURED IN | TX ND |

| NEW THD02400K | | THD02200K | | THD01900K | |
|------------------------|------------------|------------------------|------------------|------------------------|------------------|
| TANK GALLON SIZE | 2,400 | TANK GALLON SIZE | 2,200 | TANK GALLON SIZE | 1,900 |
| FRAME | ✓ | FRAME | ✓ | FRAME | ✓ |
| MOUNTING PINS INCLUDED | ✓ | MOUNTING PINS INCLUDED | ✓ | MOUNTING PINS INCLUDED | ✓ |
| DIMENSIONS (LxWxH) | 149" x 96" x 72" | DIMENSIONS (LxWxH) | 131" x 71" x 84" | DIMENSIONS (LxWxH) | 131" x 71" x 73" |
| LID SIZE | 16" | LID SIZE | 16" | LID SIZE | 16" |
| LID TYPE | STAINLESS STEEL | LID TYPE | STAINLESS STEEL | LID TYPE | STAINLESS STEEL |
| SPECIFIC GRAVITY | 1.9 | SPECIFIC GRAVITY | 1.9 | SPECIFIC GRAVITY | 1.9 |
| COLORS* | TEAL, BLACK | COLORS* | TEAL, BLACK | COLORS* | TEAL, BLACK |
| MANUFACTURED IN | ND | MANUFACTURED IN | ND | MANUFACTURED IN | ND |

| THD01600K | | THD01200K | | THD01010K | |
|------------------------|------------------|------------------------|------------------|------------------------|------------------|
| TANK GALLON SIZE | 1,600 | TANK GALLON SIZE | 1,200 | TANK GALLON SIZE | 1,010 |
| FRAME | ✓ | FRAME | ✓ | FRAME | ✓ |
| MOUNTING PINS INCLUDED | ✓ | MOUNTING PINS INCLUDED | ✓ | MOUNTING PINS INCLUDED | ✓ |
| DIMENSIONS (LxWxH) | 131" x 71" x 68" | DIMENSIONS (LxWxH) | 103" x 71" x 64" | DIMENSIONS (LxWxH) | 130" x 49" x 60" |
| LID SIZE | 16" | LID SIZE | 16" | LID SIZE | 59" |
| LID TYPE | STAINLESS STEEL | LID TYPE | POLY | LID TYPE | POLY |
| SPECIFIC GRAVITY | 1.9 | SPECIFIC GRAVITY | 1.9 | SPECIFIC GRAVITY | 1.9 |
| COLORS* | TEAL, BLACK | COLORS* | TEAL, BLACK | COLORS* | TEAL, BLACK |
| MANUFACTURED IN | ND | MANUFACTURED IN | ND | MANUFACTURED IN | TX |

| THD01000K | | THD00500K | | THD00400K | |
|------------------------|-----------------|------------------------|-----------------|------------------------|-----------------|
| TANK GALLON SIZE | 1,100 | TANK GALLON SIZE | 550 | TANK GALLON SIZE | 400 |
| FRAME | ✓ | FRAME | ✓ | FRAME | ✓ |
| MOUNTING PINS INCLUDED | ✓ | MOUNTING PINS INCLUDED | ✓ | MOUNTING PINS INCLUDED | ✓ |
| DIMENSIONS (LxWxH) | 95" x 60" x 71" | DIMENSIONS (LxWxH) | 80" x 57" x 50" | DIMENSIONS (LxWxH) | 74" x 46" x 44" |
| LID SIZE | 16" | LID SIZE | 16" | LID SIZE | 16" |
| LID TYPE | POLY | LID TYPE | POLY | LID TYPE | POLY |
| SPECIFIC GRAVITY | 1.9 | SPECIFIC GRAVITY | 1.9 | SPECIFIC GRAVITY | 1.9 |
| COLORS* | TEAL, BLACK | COLORS* | TEAL, BLACK | COLORS* | TEAL, BLACK |
| MANUFACTURED IN | ND | MANUFACTURED IN | ND | MANUFACTURED IN | ND |

| THD00250K | |
|------------------------|-----------------|
| TANK GALLON SIZE | 260 |
| FRAME | ✓ |
| MOUNTING PINS INCLUDED | ✓ |
| DIMENSIONS (LxWxH) | 55" x 47" x 38" |
| LID SIZE | 16" |
| LID TYPE | POLY |
| SPECIFIC GRAVITY | 1.9 |
| COLORS* | TEAL, BLACK |
| MANUFACTURED IN | ND |

*Yellow & White are available upon special request.



INCREASE LOAD STABILITY.

Break up waves and prevent surge effects in your transport tank with our built-tough internal tank baffle, now available for select sizes of Freestanding and Sump Bottom transport tanks.

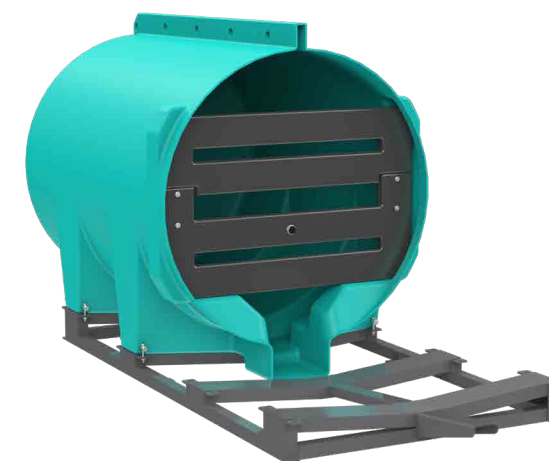

AVAILABLE FOR:

- 1,010 GALLON THF & THD
- 2,400 GALLON THF & THD
- 2,800 GALLON THF & THD
- 3,200 GALLON THF & THD
- 3,600 GALLON THF & THD

| NEW THD03600 | | THD03200 | | THD02800 | |
|------------------------|-------------------|------------------------|------------------|------------------------|------------------|
| TANK GALLON SIZE | 3,600 | TANK GALLON SIZE | 3,200 | TANK GALLON SIZE | 2,800 |
| FRAME | ✗ | FRAME | ✗ | FRAME | ✗ |
| MOUNTING PINS INCLUDED | ✗ | MOUNTING PINS INCLUDED | ✗ | MOUNTING PINS INCLUDED | ✗ |
| DIMENSIONS (LxWxH) | 145" x 96" x 100" | DIMENSIONS (LxWxH) | 145" x 96" x 88" | DIMENSIONS (LxWxH) | 145" x 96" x 80" |
| LID SIZE | 16" | LID SIZE | 16" | LID SIZE | 16" |
| LID TYPE | STAINLESS STEEL | LID TYPE | STAINLESS STEEL | LID TYPE | STAINLESS STEEL |
| SPECIFIC GRAVITY | 1.9 | SPECIFIC GRAVITY | 1.9 | SPECIFIC GRAVITY | 1.9 |
| COLORS* | TEAL, BLACK | COLORS* | TEAL, BLACK | COLORS* | TEAL, BLACK |
| MANUFACTURED IN | | MANUFACTURED IN | | MANUFACTURED IN | |

| NEW THD02400 | | THD02200 | | THD01900 | |
|------------------------|------------------|------------------------|------------------|------------------------|------------------|
| TANK GALLON SIZE | 2,400 | TANK GALLON SIZE | 2,200 | TANK GALLON SIZE | 1,900 |
| FRAME | ✗ | FRAME | ✗ | FRAME | ✗ |
| MOUNTING PINS INCLUDED | ✗ | MOUNTING PINS INCLUDED | ✗ | MOUNTING PINS INCLUDED | ✗ |
| DIMENSIONS (LxWxH) | 149" x 96" x 71" | DIMENSIONS (LxWxH) | 131" x 71" x 84" | DIMENSIONS (LxWxH) | 131" x 71" x 73" |
| LID SIZE | 16" | LID SIZE | 16" | LID SIZE | 16" |
| LID TYPE | STAINLESS STEEL | LID TYPE | STAINLESS STEEL | LID TYPE | STAINLESS STEEL |
| SPECIFIC GRAVITY | 1.9 | SPECIFIC GRAVITY | 1.9 | SPECIFIC GRAVITY | 1.9 |
| COLORS* | TEAL, BLACK | COLORS* | TEAL, BLACK | COLORS* | TEAL, BLACK |
| MANUFACTURED IN | | MANUFACTURED IN | | MANUFACTURED IN | |

| THD01600 | | THD01200 | | THD01010 | |
|------------------------|------------------|------------------------|------------------|------------------------|------------------|
| TANK GALLON SIZE | 1,600 | TANK GALLON SIZE | 1,200 | TANK GALLON SIZE | 1,010 |
| FRAME | ✗ | FRAME | ✗ | FRAME | ✗ |
| MOUNTING PINS INCLUDED | ✗ | MOUNTING PINS INCLUDED | ✗ | MOUNTING PINS INCLUDED | ✗ |
| DIMENSIONS (LxWxH) | 131" x 71" x 68" | DIMENSIONS (LxWxH) | 103" x 71" x 64" | DIMENSIONS (LxWxH) | 130" x 49" x 59" |
| LID SIZE | 16" | LID SIZE | 16" | LID SIZE | 16" |
| LID TYPE | STAINLESS STEEL | LID TYPE | POLY | LID TYPE | POLY |
| SPECIFIC GRAVITY | 1.9 | SPECIFIC GRAVITY | 1.9 | SPECIFIC GRAVITY | 1.9 |
| COLORS* | TEAL, BLACK | COLORS* | TEAL, BLACK | COLORS* | TEAL, BLACK |
| MANUFACTURED IN | | MANUFACTURED IN | | MANUFACTURED IN | |

| THD01000 | | THD00500 | | THD00400 | |
|------------------------|-----------------|------------------------|-----------------|------------------------|-----------------|
| TANK GALLON SIZE | 1,100 | TANK GALLON SIZE | 550 | TANK GALLON SIZE | 400 |
| FRAME | ✗ | FRAME | ✗ | FRAME | ✗ |
| MOUNTING PINS INCLUDED | ✗ | MOUNTING PINS INCLUDED | ✗ | MOUNTING PINS INCLUDED | ✗ |
| DIMENSIONS (LxWxH) | 95" x 60" x 71" | DIMENSIONS (LxWxH) | 80" x 57" x 49" | DIMENSIONS (LxWxH) | 74" x 46" x 43" |
| LID SIZE | 16" | LID SIZE | 16" | LID SIZE | 16" |
| LID TYPE | POLY | LID TYPE | POLY | LID TYPE | POLY |
| SPECIFIC GRAVITY | 1.9 | SPECIFIC GRAVITY | 1.9 | SPECIFIC GRAVITY | 1.9 |
| COLORS* | TEAL, BLACK | COLORS* | TEAL, BLACK | COLORS* | TEAL, BLACK |
| MANUFACTURED IN | | MANUFACTURED IN | | MANUFACTURED IN | |

| THD00250 | | MOUNTING PINS | |
|------------------------|-----------------|--|-------------|
| TANK GALLON SIZE | 260 | TANK GALLON SIZE | PINS NEEDED |
| FRAME | ✗ | 3,200 - 1,600 | 8 x AZP04 |
| MOUNTING PINS INCLUDED | ✗ | 1,200 | 6 x AZP04 |
| DIMENSIONS (LxWxH) | 55" x 47" x 36" | 1,000 - 500 | 6 x AZP03 |
| LID SIZE | 16" | 400 | 4 x AZP02 |
| LID TYPE | POLY | 250 | 4 x AZP01 |
| SPECIFIC GRAVITY | 1.9 | *Mounting pins sold separately when tank is purchased without frame. | |
| COLORS* | TEAL, BLACK | | |
| MANUFACTURED IN | | | |

*Yellow & White are available upon special request.



ELIMINATE THE NEED FOR A FRAME.

Reduce the height of the tank and eliminate the need for a frame with tank wedges under each leg. Only for use with 3,600, 3,200, 2,800 and 2,400 gallon Sump Bottom (THD) tanks.

TANK WEDGES

| PRODUCT CODE | AMOUNT NEEDED |
|--------------|---------------|
| AZSW0001 | 8 |

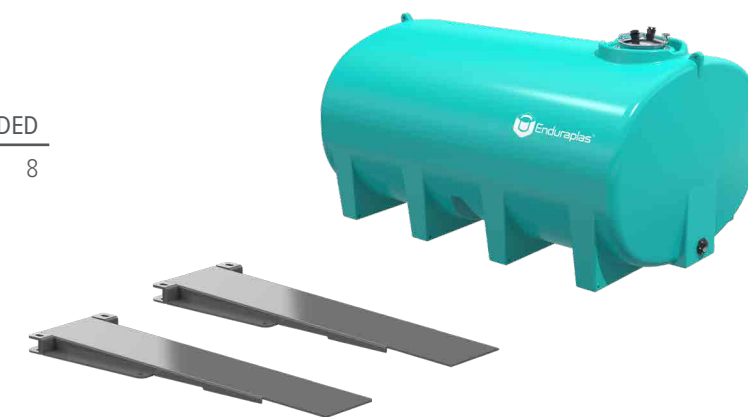

THE ANTI- SPLASH™ LID

A transport tank is only as strong as its lid. When you brake, your tank's lid must withstand up to 3,200 gallons of sloshing liquid. Our Anti-Splash™ Lid is constructed of tough, corrosion-resistant stainless steel that keeps your heaviest loads from breaking out of the lid and wasting your valuable liquids. And thanks to its heavy-duty locking mechanism, this lid is tough to break into as well.



DURABLE BY DESIGN: OUR TORTURE TESTING PROTOCOL

Before any of our products are released to the market, they undergo a battery of tests to simulate real-world use and abuse.

Our high-quality polyethylene and rotomolded construction makes every Enduraplas product resistant to cracks, dents, and punctures. We subject our products to extreme temperatures, rough terrain, and heavy loads to ensure that they can handle whatever the job throws their way.

We are proud to say that our products have earned a reputation for being the toughest and most reliable in the nation. Farmers and everyday people across the country rely on our equipment day in and day out to help them get their work done efficiently and effectively.

We know that the success of our customers depends on the quality of our products, and that's why we take our commitment to durability and reliability so seriously.



**TESTED FOR
TOUGHNESS**

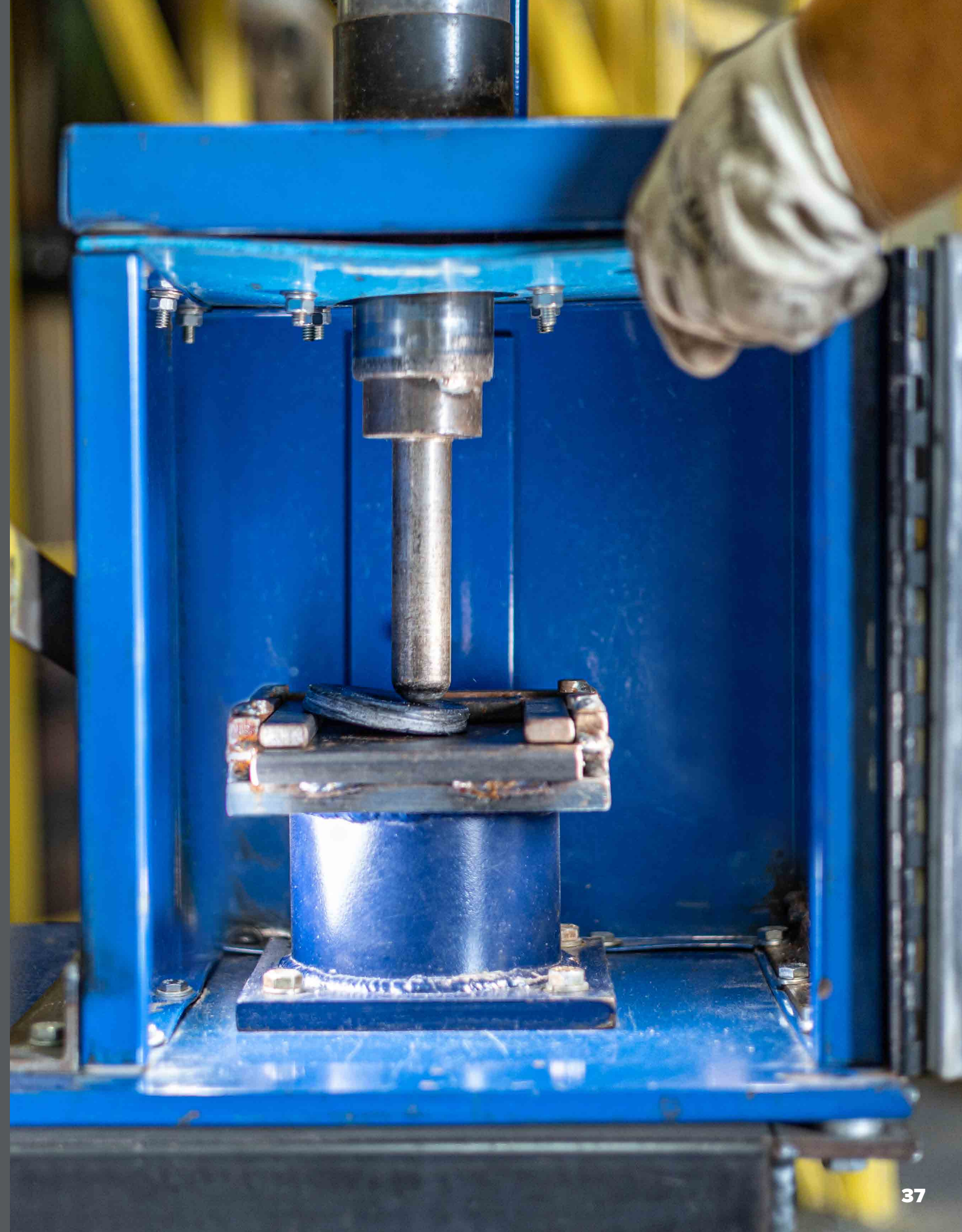

TRAILERS



NURSE TRAILERS

SELECT & LIMITED NURSE TRAILERS



TEAL



BLACK



BUILT FOR THE LONG HAUL

Our nurse trailers are built on heavy-duty, tube frames with internal wiring to eliminate common failure points and is equipped with one of our pin-mounted, thick-walled transport tanks. Take your load from farm roads to public roads with the smoothest pulling trailer in America.

FULL DOT PACKAGE

All Limited Series trailers come with lights, brakes & fenders that comply with DOT standards.

PIN-MOUNT™ SYSTEM

The molded-in mounting lugs combined with heavy-duty steel pins will keep this tank fixed without movement.

HEAVY-DUTY TUBE FRAME

This unit is powder coated and ready for abuse. All wires are protected inside the tube and built-in hose holders are included.

ANTI-SPLASH™ STAINLESS LID

Lockable and spill-proof, this lid keeps liquid in while traveling on rough terrain. *Only on tanks 1,600 gallons or larger.

AUTO-DRAIN™ SUMP BASE

The sloped tank base channels every ounce of liquid to the drain.

BUILT-IN STEP

A conveniently placed step makes it easier to access your tank lid.

THE SELECT SERIES



Our Select Series nurse trailers are the perfect solution for efficient liquid transport on your farm or ranch. With a high-quality, virtually indestructible poly tank and a Honda® engine, the Select Series is an overbuilt workhorse at an affordable price. Please note that it is not DOT approved. Its design is tailored to meet the specific needs of on-farm liquid transport, making it the ideal choice for your private agricultural operations. Built with the toughest materials and meticulous attention to detail, the Select Series allows you to only pay for what you need.

THE LIMITED SERIES



Safety is paramount when it comes to transporting liquids on public roads, and our Limited Series nurse trailer prioritizes your peace of mind. Fully equipped with a Honda® engine, a Banjo® pump, and DOT-approved lights, brakes, and fenders, this trailer meets and exceeds all DOT regulations. With its heavy-duty construction, thoughtful design, and our innovative Pin Mount™ system, the Limited Series nurse trailer lets you hit the road with ease.

SPECIFICATIONS SELECT SERIES



1,010 SELECT SERIES

| | | | |
|-----------------------|--|-----------------------|--|
| TANK GALLON SIZE | 1,010 | TANK GALLON SIZE | 1,100 |
| DIMENSIONS (LxWxH) | 195" x 73" x 78" | DIMENSIONS (LxWxH) | 154" x 85" x 88" |
| DOT COMPLIANT | ✗ | DOT COMPLIANT | ✗ |
| AXLE (S) | 2 x 7,000 SLIPPER SPRING | AXLE (S) | 2 x 7,000 SLIPPER SPRING |
| TIRES | 235/80 R16 10 PLY HWY TIRE ON AG WHEEL | TIRES | 235/80 R16 10 PLY HWY TIRE ON AG WHEEL |
| BRAKES | ✗ | BRAKES | ✗ |
| FENDERS | ✗ | FENDERS | ✗ |
| LIGHTS | ✗ | LIGHTS | ✗ |
| ELECTRICAL PLUG | ✗ | ELECTRICAL PLUG | ✗ |
| HITCH TYPE | 20,000 LBS. CLEVIS | HITCH TYPE | 20,000 LBS. CLEVIS |
| TANK TYPE | SUMP BOTTOM (THD) | TANK TYPE | SUMP BOTTOM (THD) |
| TANK COLOR | TEAL, BLACK | TANK COLOR | TEAL, BLACK |
| MOTOR | HONDA® GX160 5.5 HP | MOTOR | HONDA® GX160 5.5 HP |
| PUMP | 2" BANJO® CENTRIFUGAL POLY, 195 GPM | PUMP | 2" BANJO® CENTRIFUGAL POLY, 195 GPM |
| VALVE FITTINGS | 2" BANJO® MANIFOLD | VALVE FITTINGS | 2" BANJO® MANIFOLD |
| HOSE SIZE / TYPE | 2" / BLACK ENFORCER | HOSE SIZE / TYPE | 2" / BLACK ENFORCER |
| DISCHARGE HOSE LENGTH | 20' | DISCHARGE HOSE LENGTH | 20' |
| DRY WEIGHT (LBS) | 1,400 | DRY WEIGHT (LBS) | 1,610 |
| MANUFACTURED IN | | MANUFACTURED IN | |

1,100 SELECT SERIES



1,200 SELECT SERIES

| | | | |
|-----------------------|--|-----------------------|--|
| TANK GALLON SIZE | 1,200 | TANK GALLON SIZE | 1,600 |
| DIMENSIONS (LxWxH) | 172" x 95" x 85" | DIMENSIONS (LxWxH) | 205" x 110" x 100" |
| DOT COMPLIANT | ✗ | DOT COMPLIANT | ✗ |
| AXLE (S) | 2 x 7,000 SLIPPER SPRING | AXLE (S) | 2 x 10,000 SLIPPER SPRING |
| TIRES | 235/80 R16 10 PLY HWY TIRE ON AG WHEEL | TIRES | 425/65 R22.5 IMPLEMENT TIRE ON AG WHEEL |
| BRAKES | ✗ | BRAKES | ELECTRIC WITH EMERGENCY BREAKAWAY (1 AXLE) |
| FENDERS | ✗ | FENDERS | ✓ |
| LIGHTS | ✗ | LIGHTS | ✗ |
| ELECTRICAL PLUG | ✗ | ELECTRICAL PLUG | 7 POLE RV PLUG |
| HITCH TYPE | 20,000 LBS. CLEVIS | HITCH TYPE | 20,000 LBS. CLEVIS |
| TANK TYPE | SUMP BOTTOM (THD) | TANK TYPE | SUMP BOTTOM (THD) |
| TANK COLOR | TEAL, BLACK | TANK COLOR | TEAL, BLACK |
| MOTOR | HONDA® GX160 5.5 HP | MOTOR | HONDA® GX200 6.5 HP |
| PUMP | 2" BANJO® CENTRIFUGAL POLY, 195 GPM | PUMP | 3" BANJO® CENTRIFUGAL POLY, 293 GPM |
| VALVE FITTINGS | 2" BANJO® MANIFOLD | VALVE FITTINGS | 3" BANJO® MANIFOLD |
| HOSE SIZE / TYPE | 2" / BLACK ENFORCER | HOSE SIZE / TYPE | 3" / BLACK ENFORCER |
| DISCHARGE HOSE LENGTH | 20' | DISCHARGE HOSE LENGTH | 20' |
| DRY WEIGHT (LBS) | 1,940 | DRY WEIGHT (LBS) | 3,800 |
| MANUFACTURED IN | | MANUFACTURED IN | |

1,600 SELECT SERIES



1,200 CONE BOTTOM SELECT SERIES

| | |
|-----------------------|--|
| TANK GALLON SIZE | 1,200 |
| DIMENSIONS (LxWxH) | 165" x 95" x 100" |
| DOT COMPLIANT | X |
| AXLE (S) | 2 x 7,000 SLIPPER SPRING |
| TIRES | 235/80 R16 10 PLY HWY TIRE ON AG WHEEL |
| BRAKES | X |
| FENDERS | X |
| LIGHTS | X |
| ELECTRICAL PLUG | X |
| HITCH TYPE | 20,000 LBS. CLEVIS |
| TANK TYPE | VERTICAL CONE BOTTOM (THC) |
| TANK COLOR | TEAL, BLACK |
| MOTOR | HONDA® GX160 5.5 HP |
| PUMP | 2" BANJO® CENTRIFUGAL POLY, 195 GPM |
| VALVE FITTINGS | 2" BANJO® MANIFOLD |
| HOSE SIZE / TYPE | 2" / BLACK ENFORCER |
| DISCHARGE HOSE LENGTH | 20' |
| DRY WEIGHT (LBS) | 1,940 |
| MANUFACTURED IN | ND |

30 GAL MIX CONE

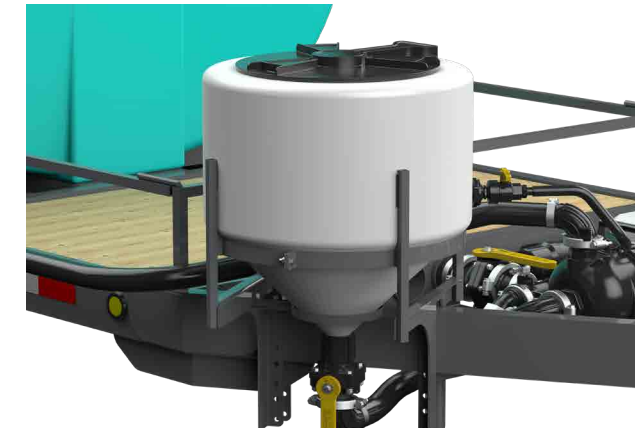

30 GAL MIX CONE WITH CHEMBLADE



FENDER BASKET KIT



SPECIFICATIONS LIMITED SERIES



1,010 LIMITED SERIES

| | | | |
|-----------------------|--|-----------------------|--|
| TANK GALLON SIZE | 1,010 | TANK GALLON SIZE | 1,100 |
| DIMENSIONS (LxWxH) | 240" x 73" x 78" | DIMENSIONS (LxWxH) | 205" x 85" x 88" |
| TOTE DECK | 4 FT | TOTE DECK | 4 FT |
| DOT COMPLIANT | ✓ | DOT COMPLIANT | ✓ |
| AXLE (S) | 2 x 7,000 SLIPPER SPRING | AXLE (S) | 2 x 7,000 SLIPPER SPRING |
| TIRES | 235/80 R16 10 PLY DOT TIRE & WHEEL | TIRES | 235/80 R16 10 PLY DOT TIRE & WHEEL |
| BRAKES | ELECTRIC W/ EMERGENCY BREAKAWAY (2 x AXLE) | BRAKES | ELECTRIC W/ EMERGENCY BREAKAWAY (2 x AXLE) |
| FENDERS | ✓ | FENDERS | ✓ |
| LIGHTS | DOT COMPLIANT CLEARANCE/STOP/TURN/TAIL/LICENSE | LIGHTS | DOT COMPLIANT CLEARANCE/STOP/TURN/TAIL/LICENSE |
| ELECTRICAL PLUG | 7 POLE RV PLUG | ELECTRICAL PLUG | 7 POLE RV PLUG |
| HITCH TYPE | 20,000 LBS. CLEVIS 2 - 5/16" BALL | HITCH TYPE | 20,000 LBS. CLEVIS 2 - 5/16" BALL |
| TANK TYPE | SUMP BOTTOM (THD) | TANK TYPE | SUMP BOTTOM (THD) |
| TANK COLOR | TEAL, BLACK | TANK COLOR | TEAL, BLACK |
| MOTOR | HONDA® GX160 5.5 HP | MOTOR | HONDA® GX160 5.5 HP |
| PUMP | 2" BANJO® CENTRIFUGAL POLY, 195 GPM | PUMP | 2" BANJO® CENTRIFUGAL POLY, 195 GPM |
| VALVE FITTINGS | 2" BANJO® MANIFOLD | VALVE FITTINGS | 2" BANJO® MANIFOLD |
| HOSE SIZE / TYPE | 2" / BLACK ENFORCER | HOSE SIZE / TYPE | 2" / BLACK ENFORCER |
| DISCHARGE HOSE LENGTH | 20' | DISCHARGE HOSE LENGTH | 20' |
| DRY WEIGHT (LBS) | 1,620 | DRY WEIGHT (LBS) | 1,620 |
| MANUFACTURED IN | TEXAS | MANUFACTURED IN | NORTH DAKOTA |

1,100 LIMITED SERIES

1,200 LIMITED SERIES

| | | | |
|-----------------------|--|-----------------------|--|
| TANK GALLON SIZE | 1,200 | TANK GALLON SIZE | 1,600 |
| DIMENSIONS (LxWxH) | 220" x 93" x 85" | DIMENSIONS (LxWxH) | 230" x 102" x 95" |
| TOTE DECK | 4 FT | TOTE DECK | 4 FT |
| DOT COMPLIANT | ✓ | DOT COMPLIANT | ✓ |
| AXLE (S) | 2 x 7,000 SLIPPER SPRING | AXLE (S) | 2 x 7,000 SLIPPER SPRING |
| TIRES | 235/80 R16 10 PLY DOT TIRE & WHEEL | TIRES | 235/75 R17.5 18 PLY DOT TIRE & WHEEL |
| BRAKES | ELECTRIC W/ EMERGENCY BREAKAWAY (2 x AXLE) | BRAKES | ELECTRIC W/ EMERGENCY BREAKAWAY (2 x AXLE) |
| FENDERS | ✓ | FENDERS | ✓ |
| LIGHTS | DOT COMPLIANT CLEARANCE/STOP/TURN/TAIL/LICENSE | LIGHTS | DOT COMPLIANT CLEARANCE/STOP/TURN/TAIL/LICENSE |
| ELECTRICAL PLUG | 7 POLE RV PLUG | ELECTRICAL PLUG | 7 POLE RV PLUG |
| HITCH TYPE | 20,000 LBS. CLEVIS 2 - 5/16" BALL | HITCH TYPE | 20,000 LBS. CLEVIS 2 - 5/16" BALL |
| TANK TYPE | SUMP BOTTOM (THD) | TANK TYPE | SUMP BOTTOM (THD) |
| TANK COLOR | TEAL, BLACK | TANK COLOR | TEAL, BLACK |
| MOTOR | HONDA® GX160 5.5 HP | MOTOR | HONDA® GX200 6.5 HP |
| PUMP | 2" BANJO® CENTRIFUGAL POLY, 195 GPM | PUMP | 3" BANJO® CENTRIFUGAL POLY, 293 GPM |
| VALVE FITTINGS | 2" BANJO® MANIFOLD | VALVE FITTINGS | 3" BANJO® MANIFOLD |
| HOSE SIZE / TYPE | 3" / BLACK ENFORCER | HOSE SIZE / TYPE | 3" / BLACK ENFORCER |
| DISCHARGE HOSE LENGTH | 20' | DISCHARGE HOSE LENGTH | 20' |
| DRY WEIGHT (LBS) | 2,035 | DRY WEIGHT (LBS) | 3,350 |
| MANUFACTURED IN | NORTH DAKOTA | MANUFACTURED IN | NORTH DAKOTA |

1,600 LIMITED SERIES



1,200 CONE BOTTOM LIMITED SERIES

| | |
|-----------------------|--|
| TANK GALLON SIZE | 1,200 |
| DIMENSIONS (LxWxH) | 215" x 95" x 100" |
| DOT COMPLIANT | ✓ |
| AXLE (S) | 2 x 7,000 SLIPPER SPRING |
| TIRES | 235/80 R16 10 PLY HWY TIRE ON AG WHEEL |
| BRAKES | ELECTRIC W/ EMERGENCY BREAKAWAY (2 x AXLE) |
| FENDERS | ✓ |
| LIGHTS | DOT COMPLIANT CLEARANCE/STOP/TURN/TAIL/LICENSE |
| ELECTRICAL PLUG | 7 POLE RV PLUG |
| HITCH TYPE | 20,000 LBS. CLEVIS 2 - 5/16" BALL |
| TANK TYPE | VERTICAL CONE BOTTOM (THC) |
| TANK COLOR | TEAL, BLACK |
| MOTOR | HONDA® GX160 5.5 HP |
| PUMP | 2" BANJO® CENTRIFUGAL POLY, 195 GPM |
| VALVE FITTINGS | 2" BANJO® MANIFOLD |
| HOSE SIZE / TYPE | 2" / BLACK ENFORCER |
| DISCHARGE HOSE LENGTH | 20' |
| DRY WEIGHT (LBS) | 2,035 |
| MANUFACTURED IN | ND |

30 GAL MIX CONE



30 GAL MIX CONE WITH CHEMBLADE



FENDER BASKET KIT



THE PIN-MOUNT™

Our transport tanks mount using a superior system of heavy-duty mounting pins and molded-in lugs, giving you a safer, stronger, and easier-to-use system than finicky mounting hoops and bands.

In our torture test, the Pin-Mount™ system withstood over 26,000 lbs. of force when we filled a tank with water and suspended it upside down from a crane.



COONE TRAILERS

DOUBLE & TRIPLE CONE BOTTOM TRAILERS



TEAL



BLACK



ON-SITE LIQUID STORAGE

Our double and triple cone trailers take everything that makes our 100% draining cone bottom tanks the best in the industry—from their ribbed walls to their reinforced roofs—and puts them on an easily moveable trailer for those who need liquid storage in different locations throughout the year.

STRONG-X™ ROOF DESIGN

The beefed up roof structure with molded-in truss-like supports eliminates collapsing in extreme weather conditions.

THICK-WALL™ DESIGN

Extra-thick walls provide unmatched strength and durability.

HEAVY-DUTY TUBE FRAME

This unit is powder-coated and ready for abuse. All wires are protected inside the tube and built-in hose holders are included.

RIBBED WALL™ STRUCTURE

The ribs act like belts around the tank, keeping it in shape - this reduces bulging.

DROP & RAISE TECHNOLOGY™

The unique jacking system is simple to pump and is placed at the perfect height. Raise the tanks without busting your back.

AUTO-DRAIN™ CONE BASE

The 15° cone base channels every ounce of liquid to the drain.

SPECIFICATIONS CONE TRAILERS



6,000 DOUBLE CONE

| | |
|--------------------|--|
| TANK GALLON SIZE | 2 x 3,000 |
| DIMENSIONS (LxWxH) | 21' x 100" x 146" - 158" |
| AXLE (S) | 2 x 3,500 LBS SPINDLE |
| TIRES | 235/80 R16 10 PLY HWY TIRE ON AG WHEEL |
| **LIGHTS | DOT COMPLIANT CLEARANCE/STOP/TURN/TAIL/LICENSE |
| **ELECTRICAL PLUG | 7 POLE RV PLUG |
| HITCH TYPE | 20,000 LBS. CLEVIS |
| TANK TYPE | CONE BOTTOM (THC) |
| TANK COLOR | TEAL, BLACK |
| MOTOR | HONDA® GX160 5.5 HP |
| PUMP | 2" BANJO® CENTRIFUGAL POLY, 195 GPM |
| VALVE FITTINGS | 3" FEED / 2" BANJO® SWEEP MANIFOLD |
| HOSE SIZE / TYPE | 3" / 2" / BLACK FERTILIZER |
| DRY WEIGHT (LBS) | 2,800 |
| MANUFACTURED IN |  |



9,000 TRIPLE CONE

| | |
|---------------------|---|
| TANK GALLON SIZE | 3 x 3,000 |
| DIMENSIONS (LxWxH) | 29' x 100" x 146" - 158" |
| AXLE (S) | 2 x 3,500 LBS SPINDLE |
| TIRES | 235/80 R16 10 PLY HWY TIRE ON AG WHEEL |
| **LIGHTS | DOT COMPLIANT CLEARANCE/STOP/TURN/TAIL/LICENSE |
| **ELECTRICAL PLUG** | 7 POLE RV PLUG |
| HITCH TYPE | 20,000 LBS. CLEVIS |
| TANK TYPE | CONE BOTTOM (THC) |
| TANK COLOR | TEAL, BLACK |
| MOTOR | HONDA® GX200 6.5 HP |
| PUMP | 3" BANJO® CENTRIFUGAL POLY, 293 GPM |
| VALVE FITTINGS | 3" FEED / 3" BANJO® SWEEP MANIFOLD |
| HOSE SIZE / TYPE | 3" / 3" / BLACK FERTILIZER |
| DRY WEIGHT (LBS) | 4,090 |
| MANUFACTURED IN |  |

ACCESSORIES CONETRAILERS

RECIRCULATION KIT



SIGHT GAUGE KIT



DOT LIGHT KIT



SWIFT BLENDER[®]

CHEMICAL HANDLING SYSTEM

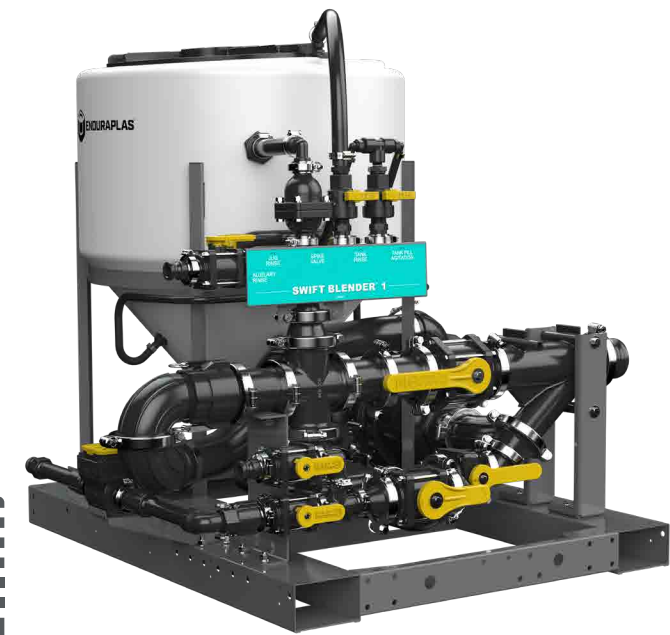

THE ULTIMATE CHEMICAL HANDLING SYSTEM

The Swift Blender[®] helps you mix your chemicals on the fly, from multiple sources, and minimizes the risk of splashing hazardous liquids back onto your skin.

VALVE-COMMAND[™] CONTROLS

Placed at eye level and within reach, the visual controls help you choose the right valve at the right time.

ROCKET-BLADE[™] JUG CUTTER

Place the jug in the right position and empty any dry mix or liquid in seconds. Let the knife do the dirty work.

FAST-FLOW[™] DESIGN

Engineered with sweep elbows and as much straight plumbing as possible, filling a sprayer and drawing from tanks is fast. All stops are eliminated.

PUMP-PLATFORM[™]

A built-in plate puts the pump in the right position and keeps it near the mixing cone.

DOUBLE-TOTE[™] VALVES

Draw from one tote or two, you choose.

TIME-SAVER[™] FORK-POINTS

The built-in fork slots make the entire unit a breeze to lift and load. Move it where you need it.

SPECIFICATIONS SWIFT BLENDER®

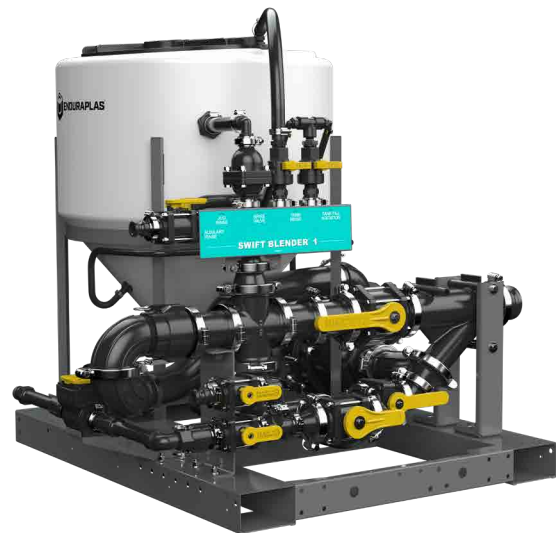

| | |
|----------------------|-----------------|
| PRODUCT CODE | CHSSB001 |
| DIMENSIONS (LxWxH) | 50" x 54" x 48" |
| LID SIZE | 12 VOLT |
| FITTING SIZE | 3" |
| VENTURI DRAW | TANK OR BULK |
| BULK CONNECTION SIZE | 1" |
| BULK CONNECTIONS | 2 |

ADD-ON OPTIONS



FLOW METER

| | |
|-----------------|------------------|
| CONNECTION SIZE | 1" |
| BRAND / TYPE | BANJO / MAGNETIC |

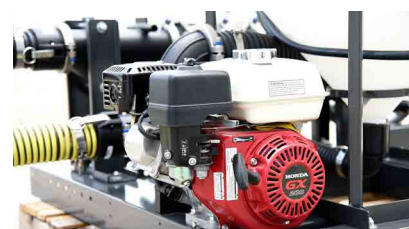

PUMP

| | |
|----------|---------|
| SIZE | 3" |
| MAX FLOW | 293 GPM |



ONLINE PARTS
STORE



TESTED FOR
TOUGHNESS



DESIGNED FOR
SAFETY

INTERNAL TANK BAFFLES

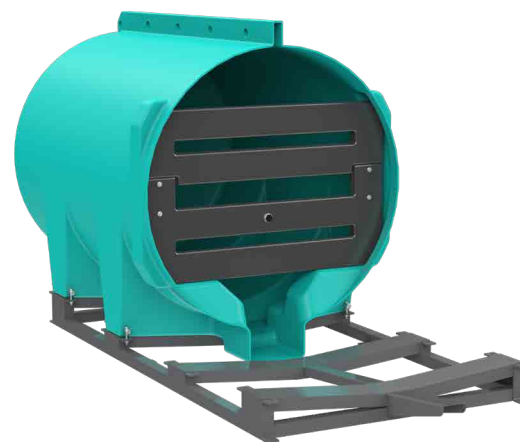

AVAILABLE FOR:

| |
|------------------------|
| 1,010 GALLON THF & THD |
| 2,400 GALLON THF & THD |
| 2,800 GALLON THF & THD |
| 3,200 GALLON THF & THD |
| 3,600 GALLON THF & THD |

SIGHT GAUGES



THREADED

FITS ON: ALL THF & THD SERIES
THV & THC 1,000 - 3,100 GAL

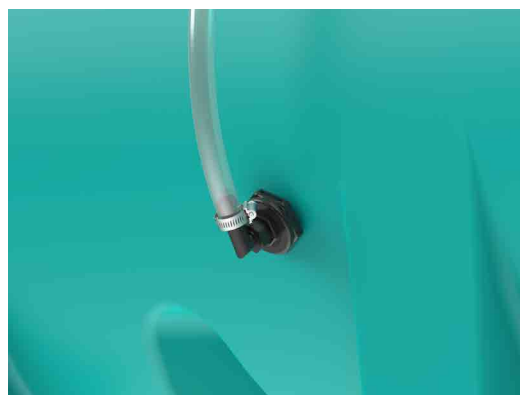

BOLTED

FITS ON: THV & THC 3,200 - 10,000 GAL

| PRODUCT CODE | TYPE |
|--------------|---------------|
| ATG01 | 3/4" THREADED |
| ATG03 | 3/4" BOLTED |

TANK LADDER



| | |
|---|-------------|
| PRODUCT CODE | AZFTLH01 |
| LADDER EXTENSION | AZFTLH01EXT |
| EXTENSION NEEDED FOR 3,500 & 4,500 GALLON TANKS | |

PUMP COVER



| | |
|--------------------|-----------------|
| PRODUCT CODE | AVPC01 |
| DIMENSIONS (LxWxH) | 20" x 15" x 17" |
| MATERIAL | POLYETHYLENE |

BAFFLE BALLS

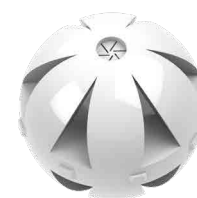

| | |
|---------------|--------------------------|
| PRODUCT CODE | AVB195 |
| DIAMETER | 7.5" |
| WEIGHT (LBS) | 0.25 |
| MATERIAL | POLYETHYLENE |
| AMOUNT NEEDED | 50 BALLS PER 100 GALLONS |

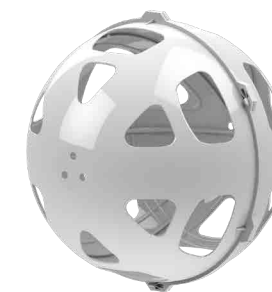

| | |
|---------------|--------------------------|
| PRODUCT CODE | AVB355 |
| DIAMETER | 14" |
| WEIGHT (LBS) | 0.8 |
| MATERIAL | POLYETHYLENE |
| AMOUNT NEEDED | 10 BALLS PER 100 GALLONS |

MIXING CONES



THM030KWH01



THM030AKWH01



THM045KWH01



THM060KWH01

| | |
|-----------------------|-------------|
| PRODUCT CODE | THM030KWH01 |
| TANK GALLON SIZE | 30 |
| DIMENSIONS (DIA. x H) | 20" x 45" |
| LID SIZE | 16" |
| FITTING SIZE | 2" |

| | |
|-----------------------|--------------|
| PRODUCT CODE | THM030AKWH01 |
| TANK GALLON SIZE | 30 |
| DIMENSIONS (DIA. x H) | 24" x 42" |
| LID SIZE | 16" |
| FITTING SIZE | 2" |

| | |
|-----------------------|-------------|
| PRODUCT CODE | THM045KWH01 |
| TANK GALLON SIZE | 45 |
| DIMENSIONS (DIA. x H) | 30" x 43" |
| LID SIZE | 16" |
| FITTING SIZE | 2" |

| | |
|-----------------------|-------------|
| PRODUCT CODE | THM060KWH01 |
| TANK GALLON SIZE | 60 |
| DIMENSIONS (DIA. x H) | 30" x 45" |
| LID SIZE | 16" |
| FITTING SIZE | 2" |

TRANSFER PUMPS



CB200P3PRO



CB200PHS



CB300PH6



CB2222PIH5

| | |
|----------------------|----------------------------|
| PRODUCT CODE | CB200P3PRO |
| MAX FLOW (GPM) | 216 |
| MAX PRESSURE (PSI) | 53 |
| START TYPE | MANUAL |
| MOTOR TYPE | BRIGGS & STRATTON® 6.5 HP |
| PUMP TYPE | 2" BANJO® CENTRIFUGAL POLY |
| SEAL TYPE | EPDM |
| HOSE CONNECTION SIZE | 2" IN / 2" OUT |

| | |
|----------------------|----------------------------|
| PRODUCT CODE | CB200PHS |
| MAX FLOW (GPM) | 216 |
| MAX PRESSURE (PSI) | 53 |
| START TYPE | MANUAL |
| MOTOR TYPE | HONDA® 5.5 HP |
| PUMP TYPE | 2" BANJO® CENTRIFUGAL POLY |
| SEAL TYPE | EPDM |
| HOSE CONNECTION SIZE | 2" IN / 2" OUT |

| | |
|----------------------|----------------------------|
| PRODUCT CODE | CB300PH6 |
| MAX FLOW (GPM) | 293 |
| MAX PRESSURE (PSI) | 35 |
| START TYPE | MANUAL |
| MOTOR TYPE | HONDA® 6.5 HP |
| PUMP TYPE | 3" BANJO® CENTRIFUGAL POLY |
| SEAL TYPE | EPDM |
| HOSE CONNECTION SIZE | 3" IN / 3" OUT |

| | |
|----------------------|---------------------------------|
| PRODUCT CODE | CB2222PIH5 |
| MAX FLOW (GPM) | 205 |
| MAX PRESSURE (PSI) | 43 |
| START TYPE | MANUAL |
| MOTOR TYPE | HONDA® 5.5 HP |
| PUMP TYPE | 2" BANJO® CENTRIFUGAL CAST IRON |
| SEAL TYPE | EPDM |
| HOSE CONNECTION SIZE | 2" IN / 2" OUT |

HOSES



| PRODUCT CODE | DESCRIPTION |
|--------------|-------------------------------------|
| CLUPEB10009 | 2" REINFORCED FLEXIBLE SUCTION HOSE |
| CLUPEB08513 | 2" REINFORCED FLEXIBLE SUCTION HOSE |
| CLUESB020001 | 3/8" EPDM SPRAY HOSE 200 PSI |
| CLUESB020002 | 1/2" EPDM SPRAY HOSE 200 PSI |
| CLUESB020004 | 3/4" EPDM SPRAY HOSE 200 PSI |
| CLUVGC03504 | 3/4" CLEAR VINYL HOSE |
| CLUESB020005 | 1" EPDM SPRAY HOSE 200 PSI |

LIDS

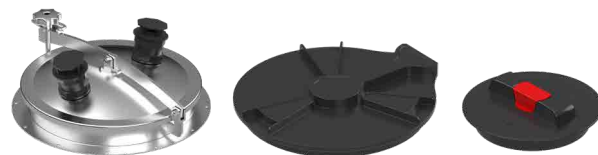

| PRODUCT CODE | DESCRIPTION |
|-----------------|-----------------------------|
| CFLS16HVCONVKIT | 16" STAINLESS STEEL LID |
| CFLP16HV | 16" HINGED - 3" VENTED LID |
| CA356060 | 16" HINGED - 2" VENTED LID |
| CA3511221 | 8" THREADED - VENTED LID |
| CVTL06 | 6" THREADED VENTED LID ONLY |
| CG839113021 | 4" THREADED VENTED LID ONLY |



WE'VE GOT YOU COVERED

FIND MORE PARTS & ACCESSORIES
ONLINE AT PARTS.ENDURAPLAS.COM



PROUDLY MADE IN THE USA



SPRAYERS



FIELD BOSS®

UTV SPRAYER



ELITE FEATURES AT AFFORDABLE PRICES

Meet the sprayer that's built as well as the UTV you're mounting it on. The Field Boss® sprayer family is feature packed, with an algae-blocking tank, a low center of gravity, a range of pump options, and built-in fork points that make it easy to remove from your UTV when you're done spraying.

SWING ARM™

All controls are at your fingertips and within reach from the UTV cab. Hoses are protected and out of sight.

LIGHT-BLOCK™ TECHNOLOGY

Algae needs light to grow. This algae-resistant material keeps the sunlight out and the spray liquid pure.

SPRAY-COMMAND™ CONTROLS

Select where you want to spray and at what pressure with all controls mounted to the Swing Arm™.

QUICK-ATTACH™ BOOM BRACKETS

Built-in boom connection points to save time and hassle when removing and attaching a spray boom.

TIME-SAVER™ FORK POINTS

The built-in fork slots makes the entire unit a breeze to lift and load.

AUTO-DRAIN™ SUMP BASE

The sloped tank base channels every ounce of spray chemical to the drain.

SPECIFICATIONS FIELD BOSS®



FIELD BOSS® 365 60 GALLON

| | |
|---------------------------|---------------------|
| PRODUCT CODE | SFB060FG225GH |
| DIMENSIONS (LxWxH) | 48" x 38" x 23" |
| MOTOR | GX120 HONDA® / 4 HP |
| PUMP | CENTRIFUGAL |
| FLOW RATE (GPM) | 22.5 |
| PSI | 50 |
| HOSE LENGTH | 50' |
| SPRAY DISTANCE VERTICAL | 27' |
| SPRAY DISTANCE HORIZONTAL | 35' |
| DRY WEIGHT (LBS) | 185 |

100 GALLON

| | |
|---------------------------|---------------------|
| PRODUCT CODE | SFB100FG225GH |
| DIMENSIONS (LxWxH) | 48" x 45" x 27" |
| MOTOR | GX120 HONDA® / 4 HP |
| PUMP | CENTRIFUGAL |
| FLOW RATE (GPM) | 22.5 |
| PSI | 50 |
| HOSE LENGTH | 50' |
| SPRAY DISTANCE VERTICAL | 27' |
| SPRAY DISTANCE HORIZONTAL | 35' |
| DRY WEIGHT (LBS) | 200 |

MANUFACTURED IN



FIELD BOSS® XSTREAM 60 GALLON

| | |
|---------------------------|---------------------|
| PRODUCT CODE | SFB060FG290EX |
| DIMENSIONS (LxWxH) | 48" x 38" x 23" |
| MOTOR | GX120 HONDA® / 4 HP |
| PUMP | DIAPHRAGM |
| FLOW RATE (GPM) | 5.8 |
| PSI | 290 |
| HOSE LENGTH | 100' |
| SPRAY DISTANCE VERTICAL | 27' |
| SPRAY DISTANCE HORIZONTAL | 35' |
| DRY WEIGHT (LBS) | 185 |

100 GALLON

| | |
|---------------------------|---------------------|
| PRODUCT CODE | SFB100FG290EX |
| DIMENSIONS (LxWxH) | 48" x 45" x 27" |
| MOTOR | GX120 HONDA® / 4 HP |
| PUMP | DIAPHRAGM |
| FLOW RATE (GPM) | 5.8 |
| PSI | 290 |
| HOSE LENGTH | 100' |
| SPRAY DISTANCE VERTICAL | 37' |
| SPRAY DISTANCE HORIZONTAL | 45' |
| DRY WEIGHT (LBS) | 200 |

MANUFACTURED IN



FIELD BOSS® ECOLITE 60 GALLON

| | |
|---------------------------|-----------------|
| PRODUCT CODE | SFB060FG712V |
| DIMENSIONS (LxWxH) | 48" x 38" x 23" |
| MOTOR | 12 VOLT |
| PUMP | DIAPHRAGM |
| FLOW RATE (GPM) | 7 |
| PSI | 60 |
| HOSE LENGTH | 50' |
| SPRAY DISTANCE VERTICAL | 27' |
| SPRAY DISTANCE HORIZONTAL | 35' |
| DRY WEIGHT (LBS) | 180 |

100 GALLON

| | |
|---------------------------|-----------------|
| PRODUCT CODE | SFB100FG712V |
| DIMENSIONS (LxWxH) | 48" x 45" x 27" |
| MOTOR | 12 VOLT |
| PUMP | DIAPHRAGM |
| FLOW RATE (GPM) | 7 |
| PSI | 60 |
| HOSE LENGTH | 50' |
| SPRAY DISTANCE VERTICAL | 27' |
| SPRAY DISTANCE HORIZONTAL | 35' |
| DRY WEIGHT (LBS) | 195 |

MANUFACTURED IN



ADD-ON OPTIONS



SOLENOID KIT

ADD "ES" TO PRODUCT CODE

INCLUDES:
3 x Solenoids, Control Box with
Pressure Regulator & Wiring
Harness



FRESHWATER TANK

PRODUCT CODE: ASFBFWKIT

INCLUDES:
3 Gal Freshwater Tank
with Fitted Tap

ATTACHMENTS



BOOMLESS NOZZLE

PRODUCT CODE: ASBB30P
SEE PAGE 100



STEEL BOOM

PRODUCT CODE: ASBS20SS
SEE PAGE 96

FIELD BOSS® 365



PERFORMANCE

| | |
|------------------------|--------|
| BOOM SPRAYING | ●●●●●● |
| SPOT SPRAYING | ●●●●●● |
| HIGH PRESSURE SPRAYING | ●●●●●● |
| FIRE CONTROL SPRAYING | ●●●●●● |
| TREE SPRAYING | ●●●●●● |
| HIGH VOLUME SPRAYING | ●●●●●● |

FIELD BOSS® XSTREAM



PERFORMANCE

| | |
|------------------------|--------|
| BOOM SPRAYING | ●●●●●● |
| SPOT SPRAYING | ●●●●●● |
| HIGH PRESSURE SPRAYING | ●●●●●● |
| FIRE CONTROL SPRAYING | ●●●●●● |
| TREE SPRAYING | ●●●●●● |
| HIGH VOLUME SPRAYING | ●●●●●● |

FIELD BOSS® ECOLITE



PERFORMANCE

| | |
|------------------------|--------|
| BOOM SPRAYING | ●●●●●● |
| SPOT SPRAYING | ●●●●●● |
| HIGH PRESSURE SPRAYING | ●●●●●● |
| FIRE CONTROL SPRAYING | ●●●●●● |
| TREE SPRAYING | ●●●●●● |
| HIGH VOLUME SPRAYING | ●●●●●● |



**“OUR FIELD BOSS
HAS BEEN A REAL
GAME CHANGER
WHEN IT COMES TO
WEED CONTROL
ON OUR RANCH.”**

“Having the option of the 12 foot boom or the boomless nozzle gives us the ability to get to those hard to reach and tight places! And we absolutely love the controls being right at our fingertips while driving our side by side! We highly recommend to anyone that wants to KeepRanchin’!”

- BAR 7 RANCH



LAND CHAMP®

THREE-POINT TRACTOR SPRAYER



BUILT TO REDUCE ROLLOVERS

We built the Land Champ three-point tractor sprayer to make tractor spraying less of a chore... and risk. Built-in fork points make it easy to attach and an onboard freshwater tank makes it easy to flush your lines in the field. Most importantly, the Land Champ features the first sprayer tank specifically designed to help prevent tractor rollovers.



SAFE-BALANCE™ DESIGN

Because of its shape, the entire weight of the tank is shifted closer to the rear tractor wheels. A lot safer when spraying on sloped terrain.

FRESH-FLUSH™ SYSTEM

A built-in freshwater tank. Use it to flush out all plumbing lines to avoid mixing spray chemical.

LOCK-VALVE™ FILTER SYSTEM

The filter at the base of the tank can be checked or cleaned without having to empty the entire tank.

EASY-ACCESS™ LID

This easy-to-reach lid located at the side of the tank makes filling quick and simple.

QUICK-CONNECT™ BOOM PORTS

Plumb a spray boom to this sprayer in seconds with three brass screw-on fittings. Zero tools needed.

CHEM-MIX™ AGITATION

An integrated agitation creates a swirl-like motion at the base of the tank. This is what mixes the chemical with the water.

SPECIFICATIONS LAND CHAMP®



50 GALLON

| | |
|---------------------------|--------------------|
| PRODUCT CODE | SLC050FG8GR |
| DIMENSIONS (LxWxH) | 21" x 44" x 43" |
| MOTOR | PTO |
| PUMP | CAST IRON 6 ROLLER |
| FLOW RATE (GPM) | 8 |
| PSI | 300 |
| HOSE LENGTH | 15' |
| SPRAY DISTANCE VERTICAL | 27' |
| SPRAY DISTANCE HORIZONTAL | 35' |
| DRY WEIGHT (LBS) | 160 |

WITH STAINLESS STEEL PUMP

| | |
|---------------------------|---|
| PRODUCT CODE | SLC050FG8GRS |
| DIMENSIONS (LxWxH) | 21" x 44" x 43" |
| MOTOR | PTO |
| PUMP | STAINLESS STEEL 6 ROLLER |
| FLOW RATE (GPM) | 8 |
| PSI | 300 |
| HOSE LENGTH | 15' |
| SPRAY DISTANCE VERTICAL | 27' |
| SPRAY DISTANCE HORIZONTAL | 35' |
| DRY WEIGHT (LBS) | 160 |
| MANUFACTURED IN |  |



100 GALLON

| | |
|---------------------------|--------------------|
| PRODUCT CODE | SLC100FG8GR |
| DIMENSIONS (LxWxH) | 27" x 44" x 48" |
| MOTOR | PTO |
| PUMP | CAST IRON 6 ROLLER |
| FLOW RATE (GPM) | 8 |
| PSI | 300 |
| HOSE LENGTH | 15' |
| SPRAY DISTANCE VERTICAL | 27' |
| SPRAY DISTANCE HORIZONTAL | 35' |
| DRY WEIGHT (LBS) | 230 |

WITH STAINLESS STEEL PUMP

| | |
|---------------------------|---|
| PRODUCT CODE | SLC100FG8GRS |
| DIMENSIONS (LxWxH) | 27" x 44" x 48" |
| MOTOR | PTO |
| PUMP | STAINLESS STEEL 6 ROLLER |
| FLOW RATE (GPM) | 8 |
| PSI | 300 |
| HOSE LENGTH | 15' |
| SPRAY DISTANCE VERTICAL | 27' |
| SPRAY DISTANCE HORIZONTAL | 35' |
| DRY WEIGHT (LBS) | 230 |
| MANUFACTURED IN |  |



200 GALLON

| | |
|---------------------------|--------------------|
| PRODUCT CODE | SLC200FG8GR |
| DIMENSIONS (LxWxH) | 36" x 48" x 52" |
| MOTOR | PTO |
| PUMP | CAST IRON 6 ROLLER |
| FLOW RATE (GPM) | 8 |
| PSI | 300 |
| HOSE LENGTH | 15' |
| SPRAY DISTANCE VERTICAL | 27' |
| SPRAY DISTANCE HORIZONTAL | 35' |
| DRY WEIGHT (LBS) | 290 |

WITH STAINLESS STEEL PUMP

| | |
|---------------------------|---|
| PRODUCT CODE | SLC200FG8GRS |
| DIMENSIONS (LxWxH) | 36" x 48" x 52" |
| MOTOR | PTO |
| PUMP | STAINLESS STEEL 6 ROLLER |
| FLOW RATE (GPM) | 8 |
| PSI | 300 |
| HOSE LENGTH | 15' |
| SPRAY DISTANCE VERTICAL | 27' |
| SPRAY DISTANCE HORIZONTAL | 35' |
| DRY WEIGHT (LBS) | 290 |
| MANUFACTURED IN |  |

ACCESSORIES



SOLENOID KIT

ADD "ES" TO PRODUCT CODE
INCLUDES:
3 x Solenoids, Control Box with Pressure Regulator & Wiring Harness



HOSE REEL

ADD "01" TO PRODUCT CODE
INCLUDES:
100' of 3/8" Hose on a Poly Hose Reel



FRESHWATER TANK

PRODUCT CODE: ASFBFWKIT
INCLUDES:
3 Gal Freshwater Tank with Fitted Tap



STORAGE STAND

PRODUCT CODES:
50 Gal - AZKF0017KIT
100-200 Gal - AZKF0013KIT

ATTACHMENTS



BOOMLESS NOZZLE

PRODUCT CODE: ASBB30P
SEE PAGE 100



STEEL BOOM

PRODUCT CODE: ASBS20SS
SEE PAGE 96

THE SAFE-BALANCE™ TANK

We developed the Safe-Balance™ tank to help combat the No. 1 leading cause of fatal injuries on American farms.
Tractor Rollovers.

This counter-balanced tank design shifts weight closer to the tractor's rear wheels, making the load more stable when you're spraying on sloped terrain. From its reinforced

structure to its advanced features, every aspect of this tank is designed with farmers' safety as the top priority, giving you peace of mind during your daily operations.



SPOT CHIEF®

ATV SPRAYER



BIG FEATURES IN A COMPACT SIZE

When you need to spot spray hard-to-reach areas, you'll find yourself reaching for the Spot Chief® every time. This convenient spot sprayer features the same over-built construction as its larger brothers in a package that easily mounts to your ATV.

LIGHT-BLOCK™ TECHNOLOGY

Algae needs light to grow. This algae-resistant material keeps the sunlight out and the spray liquid pure.

EASY-LIFT™ HANDLES

Molded-in, solid-handle grips make loading and unloading this unit effortless.

DRAIN-CHANNEL™ SYSTEM

When slightly tilted, this tank is designed to drain every ounce of spray chemical to the handle.

ANCHOR-POINT™ STRAP GROOVES

Heavy-duty, never-fail strap grooves are built-in on both sides. This makes tying down this unit quick and hassle-free.

CHEMICAL JUG-HOLDER

A convenient place to sit your chemical jug or tools while filling the tank.

FAST-WRAP™ HOSE HOLDER

Mount the hose holders on the front or back of this sprayer and stow away the spray gun for travel.

SPECIFICATIONS SPOT CHIEF®



25 GALLON

| | |
|---------------------------|---|
| PRODUCT CODE | SSC025212V |
| DIMENSIONS (LxWxH) | 18" x 39" x 16" |
| MOTOR | 12 VOLT |
| PUMP | DIAPHRAGM |
| FLOW RATE (GPM) | 2 |
| PSI | 60 |
| HOSE LENGTH | 25' |
| SPRAY DISTANCE VERTICAL | 27' |
| SPRAY DISTANCE HORIZONTAL | 35' |
| DRY WEIGHT (LBS) | 26 |
| MANUFACTURED IN |  TX |



ONLINE PARTS
STORE



TESTED FOR
TOUGHNESS



DESIGNED FOR
SAFETY



FIRE RANGER™

FIRE CONTROL SPRAYER



FOR WHEN YOU'RE THE FIRST RESPONDER

When a farm fire threatens your property, help can be far away. We built the Fire Ranger™ sprayer to arm you with the tools you need when it's time to become the first responder. Our pickup-mounted firefighting sprayer gives you a fighting chance when it's time to protect your property from fire damage.

TIME-SAVER™ FORK-POINTS

The built-in fork slots makes the entire unit a breeze to lift and load.

POLY-FLEX™ HOSE REEL

Unlike steel, this crack-proof, easy-wind poly hose reel will flex before it breaks.

EXTENDED BLAZE-RANGE™ HOSE

Our 100' hose gets you close to the action with your safety in mind, maximizing your fire control effectiveness.

EASY-START™ HONDA® ENGINE

Within the first few pulls, this trusty, reliable engine is guaranteed to start... even after a long winter break.

POWER-HEAD™ WATER PUMP

High-pressure, high-volume and self-priming, this Honda® pump dumps a serious amount of water.

FLAME-SLAYER™ NOZZLE

With a 35' by 45' spray distance, our nozzle effectively suppresses fire from a safe distance.

SPECIFICATIONS FIRE RANGER™



250 GALLON

| | |
|---------------------------|---------------------|
| PRODUCT CODE | SMF250FG120GH |
| DIMENSIONS (LxWxH) | 80" x 47" x 38" |
| MOTOR | GX150 HONDA® 5.5 HP |
| PUMP | CENTRIFUGAL |
| FLOW RATE (GPM) | 120 |
| PSI | 100 |
| HOSE LENGTH | 100' |
| SPRAY DISTANCE VERTICAL | 35' |
| SPRAY DISTANCE HORIZONTAL | 45' |
| DRY WEIGHT (LBS) | 458 |
| MANUFACTURED IN | ND |



400 GALLON

| | |
|---------------------------|---------------------|
| PRODUCT CODE | SMF400FG120GH |
| DIMENSIONS (LxWxH) | 102" x 46" x 45" |
| MOTOR | GX150 HONDA® 5.5 HP |
| PUMP | CENTRIFUGAL |
| FLOW RATE (GPM) | 120 |
| PSI | 100 |
| HOSE LENGTH | 100' |
| SPRAY DISTANCE VERTICAL | 35' |
| SPRAY DISTANCE HORIZONTAL | 45' |
| DRY WEIGHT (LBS) | 541 |
| MANUFACTURED IN | ND |



**FAST, RESPONSIVE
CUSTOMER SUPPORT**



MADE IN USA



**ONLINE PARTS
STORE**



**LEAK-PROOF
DESIGN**



**LONGEST WARRANTY
IN THE INDUSTRY**



**DESIGNED FOR
SAFETY**



**SUPPORTIVE DEALER
NETWORK**



**TESTED FOR
TOUGHNESS**



**ROTMOLDED USING
HIGH-QUALITY MATERIAL**

FOAM RANGER™

FIRE CONTROL SPRAYER



FOR WHEN YOU'RE THE FIRST RESPONDER

When a farm fire threatens your property, help can be far away. We built the Fire and Foam Ranger™ sprayers to arm you with the tools you need when it's time to become the first responder. Our pickup-mounted firefighting sprayers offer foam and water options to give you a fighting chance when it's time to protect your property from fire damage.

TIME-SAVER™ FORK-POINTS

The built-in fork slots makes the entire unit a breeze to lift and load.

POLY-FLEX™ HOSE REEL

Unlike steel, this crack-proof, easy-wind poly hose reel will flex before it breaks.

AIR-INDUCT™ NOZZLE

This smart foam gun draws the right amount of air into the liquid to create effective foam texture.

EASY-START™ HONDA® ENGINE

Within the first few pulls, this trusty, reliable engine is guaranteed to start... even after a long winter break.

POWER-HEAD™ WATER PUMP

High-pressure, high-volume and self-priming, this Honda® pump dumps a serious amount of water.

EASY-STORE™ FOAM TANK

The built-in 15-gallon tank stores foam to save setup time with an external foam source.

SPECIFICATIONS **FOAM RANGER™**



250 GALLON

| | |
|---------------------------|---------------------|
| PRODUCT CODE | SMFF250FG120GH |
| DIMENSIONS (LxWxH) | 80" x 47" x 38" |
| MOTOR | GX150 HONDA® 5.5 HP |
| PUMP | CENTRIFUGAL |
| FLOW RATE (GPM) | 120 |
| PSI | 100 |
| FOAM TANK SIZE | 15 GALLON |
| HOSE LENGTH | 100' |
| SPRAY DISTANCE VERTICAL | 33' |
| SPRAY DISTANCE HORIZONTAL | 36' |
| DRY WEIGHT (LBS) | 493 |
| MANUFACTURED IN | ND |



400 GALLON

| | |
|---------------------------|---------------------|
| PRODUCT CODE | SMFF400FG120GH |
| DIMENSIONS (LxWxH) | 102" x 46" x 45" |
| MOTOR | GX150 HONDA® 5.5 HP |
| PUMP | CENTRIFUGAL |
| FLOW RATE (GPM) | 120 |
| PSI | 100 |
| FOAM TANK SIZE | 15 GALLON |
| HOSE LENGTH | 100' |
| SPRAY DISTANCE VERTICAL | 33' |
| SPRAY DISTANCE HORIZONTAL | 36' |
| DRY WEIGHT (LBS) | 576 |
| MANUFACTURED IN | ND |



**FAST, RESPONSIVE
CUSTOMER SUPPORT**



MADE IN USA



**ONLINE PARTS
STORE**



**LEAK-PROOF
DESIGN**



**LONGEST WARRANTY
IN THE INDUSTRY**



**DESIGNED FOR
SAFETY**



**SUPPORTIVE DEALER
NETWORK**



**TESTED FOR
TOUGHNESS**



**ROTMOLDED USING
HIGH-QUALITY MATERIAL**

ATTACHMENTS & PARTS SPRAYERS



STEEL BOOM



UP TO 30' IN A SINGLE PASS

This boom turns your Field Boss®-equipped UTV into a full-fledged spray rig, capable of covering up to 30' in one pass.

SPRING-MOUNT™ ARMS

The boom's spray arms fold when you hit an obstacle and stow away in seconds.

TRI-ZONE™ SPRAY SELECTION

Easily select left, right, and center spray channels.

EVEN-COVER™ NOZZLES

Nozzles are evenly spaced so you don't miss an inch.

ENDOFLEX BOOM FRAME™

Our new and improved boom piping is made with a specialized EPDM hose that gives you the flexibility to conquer any surface.

IMPACT-SHIELD™ NOZZLE GUARDS

Built-in shields defend your nozzles from impacts.

ACCU-VERT BOOM POSITIONING™

Accurately spray your chemicals exactly where you want them, even in windy weather conditions.

SPECIFICATIONS STEEL BOOM



12 FOOT

| | |
|--------------------------|---------------------|
| PRODUCT CODE | ASBS12SS |
| WIDTH UNFOLDED | 12' |
| WIDTH FOLDED | 51" |
| SPRAY COVERAGE | 13' |
| NUMBER OF NOZZLES | 8 |
| NOZZLE SPACING | 20" |
| MINIMUM PUMP REQUIREMENT | 2 GPM |
| MAX PUMP PRESSURE | 60 PSI |
| BOOM TYPE | POWDER COATED STEEL |
| ROUNDUP® READY | ✓ |
| WEIGHT (LBS) | 27 |

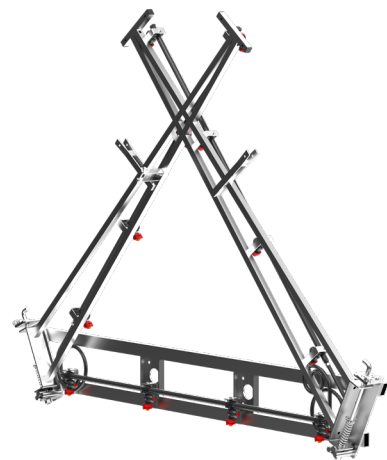

20 FOOT

| | |
|--------------------------|---------------------|
| PRODUCT CODE | ASBS20SS |
| WIDTH UNFOLDED | 20' |
| WIDTH FOLDED | 84" |
| SPRAY COVERAGE | 20' |
| NUMBER OF NOZZLES | 12 |
| NOZZLE SPACING | 20" |
| MINIMUM PUMP REQUIREMENT | 4 GPM |
| MAX PUMP PRESSURE | 60 PSI |
| BOOM TYPE | POWDER COATED STEEL |
| ROUNDUP® READY | ✓ |
| WEIGHT (LBS) | 85 |

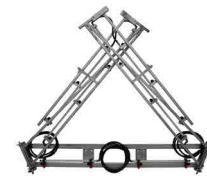

30 FOOT

| | |
|--------------------------|---------------------|
| PRODUCT CODE | ASBS30XKIT* |
| WIDTH UNFOLDED | 30' |
| WIDTH FOLDED | 84" |
| SPRAY COVERAGE | 30' |
| NUMBER OF NOZZLES | 18 |
| NOZZLE SPACING | 20" |
| MINIMUM PUMP REQUIREMENT | 7 GPM |
| MAX PUMP PRESSURE | 60 PSI |
| BOOM TYPE | POWDER COATED STEEL |
| ROUNDUP® READY | ✓ |
| WEIGHT (LBS) | 110 |

*10 FT EXTENSION KIT DESIGNED TO FIT ON A 20 FT STEEL BOOM.



RECEIVER HITCH

| | |
|------------------|-----------------|
| PRODUCT CODE: | AZFRH001 |
| HITCH SIZE: | 2" |
| COMPATIBLE WITH: | ALL STEEL BOOMS |
| WEIGHT (LBS): | 5 |

BOOMLESS NOZZLE KIT



SPRAY ANYWHERE YOUR UTV WILL GO

Our boomless nozzle is your solution to putting down liquid on terrain that's too uneven for traditional boom arms, like ditches.

ALL-TERRAIN APPLICATION

Spray fencelines, ditches, uneven ground, and places in which you can't maneuver a boom.

STOUT-MOUNT™ ATTACHMENT

Our simple, tough bracket keeps your nozzles in place even on the roughest terrain.

DUAL-SELECT™ SPRAY CHANNELS

Selectable left and right spray zones are perfect for fenceline spraying.

SPECIFICATIONS

| | |
|--------------------------|--|
| PRODUCT CODE | ASBB30P |
| SPRAY COVERAGE | 30' |
| NUMBER OF NOZZLES | 2 |
| MINIMUM PUMP REQUIREMENT | 4 GPM |
| MAX PUMP PRESSURE | 60 PSI |
| ROUNDUP® READY | |
| WEIGHT (LBS) | 5 |
| COMPATIBLE SPRAYERS | ALL FIELD BOSS® & LAND CHAMP® SPRAYERS |

SPRAY GUNS



| | |
|--------------------|-------------|
| PRODUCT CODE | CVSTAL24 |
| MAX FLOW (GPM) | 7 |
| MAX PRESSURE (PSI) | 250 |
| SPRAY PATTERN | JET / FAN |
| ADJUSTABLE SPRAY | YES |
| INLET FITTING SIZE | 3/8" |
| USED ON | SPOT CHIEF® |



| | |
|--------------------|--------------------------|
| PRODUCT CODE | CVSTAL26SH |
| MAX FLOW (GPM) | 7 |
| MAX PRESSURE (PSI) | 350 |
| SPRAY PATTERN | JET / FAN |
| ADJUSTABLE SPRAY | YES |
| INLET FITTING SIZE | 3/8" |
| USED ON | FIELD BOSS® ECOLITE, 365 |



| | |
|--------------------|---------------------|
| PRODUCT CODE | CVSTAL28 |
| MAX FLOW (GPM) | 15 |
| MAX PRESSURE (PSI) | 700 |
| SPRAY PATTERN | JET / FAN / FOG |
| ADJUSTABLE SPRAY | YES |
| INLET FITTING SIZE | 3/8" |
| USED ON | FIELD BOSS® XSTREAM |

HOSES



| PRODUCT CODE | DESCRIPTION |
|--------------|------------------------------|
| CLUESB020001 | 3/8" EPDM SPRAY HOSE 200 PSI |
| CLUESB020002 | 1/2" EPDM SPRAY HOSE 200 PSI |
| CLUESB020004 | 3/4" EPDM SPRAY HOSE 200 PSI |
| CLUVGC02502 | 1/2" CLEAR VINYL HOSE |
| CLUESB020005 | 1" EPDM SPRAY HOSE 200 PSI |

LIDS



| PRODUCT CODE | DESCRIPTION |
|--------------|-----------------------------|
| CFLP16HV | 16" HINGED - 3" VENTED LID |
| CA3511221 | 8" THREADED - VENTED LID |
| CVTL06 | 6" THREADED VENTED LID ONLY |
| CG839113021 | 4" THREADED VENTED LID ONLY |

SOLENOID KIT



| | |
|--------------|-------------------------------------|
| PRODUCT CODE | ADD "ES" TO END OF PRODUCT'S CODE |
| INCLUDES: | |
| | 3 SOLENOIDS |
| | CONTROL BOX WITH PRESSURE REGULATOR |
| | WIRING HARNESS |

GAS ENGINE PUMPS

| | |
|----------------------|-------------------|
| PRODUCT CODE | APKC04P |
| MAX FLOW (GPM) | 22 |
| MAX PRESSURE (PSI) | 57 |
| MOTOR TYPE | GX120 HONDA® /4HP |
| PUMP TYPE | CENTRIFUGAL |
| SEAL TYPE | VITON |
| HOSE CONNECTION SIZE | 1" IN / 1" OUT |
| USED ON | FIELD BOSS® 365 |

| | |
|----------------------|---------------------|
| PRODUCT CODE | APBD02 |
| MAX FLOW (GPM) | 5.8 |
| MAX PRESSURE (PSI) | 290 |
| MOTOR TYPE | GX120 HONDA® /4HP |
| PUMP TYPE | DIAPHRAGM |
| SEAL TYPE | VITON |
| HOSE CONNECTION SIZE | 3/4" IN / 1/2" OUT |
| USED ON | FIELD BOSS® XSTREAM |

ROLLER PUMPS

| | |
|----------------------|--------------------|
| PRODUCT CODE | APD19G006R |
| MAX FLOW (GPM) | 8 |
| MAX PRESSURE (PSI) | 300 |
| MOTOR TYPE | PTO |
| PUMP TYPE | 6 ROLLER |
| SEAL TYPE | VITON |
| HOSE CONNECTION SIZE | 3/4" IN / 3/4" OUT |

| | |
|----------------------|--------------------------|
| PRODUCT CODE | APD22G006R |
| MAX FLOW (GPM) | 8 |
| MAX PRESSURE (PSI) | 300 |
| MOTOR TYPE | PTO |
| PUMP TYPE | STAINLESS STEEL 6 ROLLER |
| SEAL TYPE | VITON |
| HOSE CONNECTION SIZE | 3/4" IN / 3/4" OUT |

12 VOLT PUMPS

| | |
|----------------------|-------------------------------------|
| PRODUCT CODE | APD02G060P |
| MAX FLOW (GPM) | 2 |
| MAX PRESSURE (PSI) | 60 |
| MAX AMPS | 5.7 |
| MOTOR TYPE | 12 VDC |
| PUMP TYPE | DIAPHRAGM |
| SEAL TYPE | VITON VALVES / SANTOPRENE DIAPHRAGM |
| HOSE CONNECTION SIZE | 3/8" |

| | |
|----------------------|-------------------------------------|
| PRODUCT CODE | APD07G060PGB |
| MAX FLOW (GPM) | 7 |
| MAX PRESSURE (PSI) | 60 |
| MAX AMPS | 25 |
| MOTOR TYPE | 12 VDC |
| PUMP TYPE | DIAPHRAGM |
| SEAL TYPE | VITON VALVES / SANTOPRENE DIAPHRAGM |
| HOSE CONNECTION SIZE | 1/2" |

FUEL TRANSFER TANKS



FUEL BOSS®

FUEL TRANSFER TANK



REFUELING WHEN YOU NEED IT

The Fuel Boss pickup-mounted refueling unit comes ready-to-use with a pump, gun, and auto shut-off nozzle. Diesel and DEF models help you keep your equipment in the field with minimal downtime. And thanks to their easy-lift handles, these units don't tie up your bed space when you don't need them.

CONDENSATE-ARMOUR™ MATERIAL

Unlike steel and aluminum, this polyethylene material reduces condensation build-up to minimize machinery filter damage.

DUAL-STRAIN™ FILTER SYSTEM

The first filter at the fill point eliminates muck entering the tank. The second filter at the suction hose stops debris entering the pump and the machine engine.

PUMP-SHIELD™ COVER

The pump & gun sits neat and tight out of the weather.

SELF-ACTIVATE™ SHUT-OFF NOZZLE

This well-built diesel fuel nozzle is engineered to shut off automatically when the machine is completely full.

IMPACT-FLEX™ STRUCTURE

With sturdy side walls, this workhorse is high-impact-resistant and virtually indestructible. Unlike steel or aluminum, it will consistently flex and bounce back.

EASY-LIFT™ HANDLES

Molded-in, solid handles make loading and unloading this unit effortless.

SPECIFICATIONS DIESEL FUEL BOSS®



25 GALLON

| | |
|-----------------------|---|
| PRODUCT CODE | RDU025C10D |
| DIMENSIONS (LxWxH) | 37" x 27" x 20" |
| COMPATIBLE WITH | DIESEL |
| FILL POINT | 3" |
| PUMP | VANE |
| GUN | AUTO SHUT-OFF |
| FLOW RATE (GPM) | 10 |
| ELECTRIC CABLE LENGTH | 16' |
| HOSE LENGTH | 16' |
| TANK MATERIAL TYPE | POLYETHYLENE |
| DRY WEIGHT (LBS) | 69 |
| MANUFACTURED IN |  |



50 GALLON

| | |
|-----------------------|---|
| PRODUCT CODE | RDU055C10D |
| DIMENSIONS (LxWxH) | 32" x 27" x 30" |
| COMPATIBLE WITH | DIESEL |
| FILL POINT | 3" |
| PUMP | VANE |
| GUN | AUTO SHUT-OFF |
| FLOW RATE (GPM) | 10 |
| ELECTRIC CABLE LENGTH | 16' |
| HOSE LENGTH | 16' |
| TANK MATERIAL TYPE | POLYETHYLENE |
| DRY WEIGHT (LBS) | 80 |
| MANUFACTURED IN |  |



75 GALLON

| | |
|-----------------------|---|
| PRODUCT CODE | RDU075N10D |
| DIMENSIONS (LxWxH) | 51" x 21" x 31" |
| COMPATIBLE WITH | DIESEL |
| FILL POINT | 3" |
| PUMP | VANE |
| GUN | AUTO SHUT-OFF |
| FLOW RATE (GPM) | 10 |
| ELECTRIC CABLE LENGTH | 16' |
| HOSE LENGTH | 16' |
| TANK MATERIAL TYPE | POLYETHYLENE |
| DRY WEIGHT (LBS) | 90 |
| MANUFACTURED IN |  |



100 GALLON

| | |
|-----------------------|---|
| PRODUCT CODE | RDU100S10D |
| DIMENSIONS (LxWxH) | 47" x 34" x 34" |
| COMPATIBLE WITH | DIESEL |
| FILL POINT | 3" |
| PUMP | VANE |
| GUN | AUTO SHUT-OFF |
| FLOW RATE (GPM) | 10 |
| ELECTRIC CABLE LENGTH | 16' |
| HOSE LENGTH | 16' |
| TANK MATERIAL TYPE | POLYETHYLENE |
| DRY WEIGHT (LBS) | 100 |
| MANUFACTURED IN |  |

SPECIFICATIONS DEF FUEL BOSS®



25 GALLON

| | |
|-----------------------|---|
| PRODUCT CODE | REU025C09S |
| DIMENSIONS (LxWxH) | 37" x 27" x 20" |
| COMPATIBLE WITH | DEF |
| FILL POINT | 3/4" |
| PUMP | VANE |
| GUN | AUTO SHUT-OFF |
| FLOW RATE (GPM) | 8 |
| ELECTRIC CABLE LENGTH | 21' |
| HOSE LENGTH | 20' |
| TANK MATERIAL TYPE | POLYETHYLENE |
| DRY WEIGHT (LBS) | 74 |
| MANUFACTURED IN |  |



50 GALLON

| | |
|-----------------------|---|
| PRODUCT CODE | REU055C09S |
| DIMENSIONS (LxWxH) | 32" x 27" x 30" |
| COMPATIBLE WITH | DEF |
| FILL POINT | 3/4" |
| PUMP | VANE |
| GUN | AUTO SHUT-OFF |
| FLOW RATE (GPM) | 8 |
| ELECTRIC CABLE LENGTH | 21' |
| HOSE LENGTH | 20' |
| TANK MATERIAL TYPE | POLYETHYLENE |
| DRY WEIGHT (LBS) | 85 |
| MANUFACTURED IN |  |



75 GALLON

| | |
|-----------------------|---|
| PRODUCT CODE | RDU075N09S |
| DIMENSIONS (LxWxH) | 51" x 21" x 31" |
| COMPATIBLE WITH | DEF |
| FILL POINT | 3/4" |
| PUMP | VANE |
| GUN | AUTO SHUT-OFF |
| FLOW RATE (GPM) | 8 |
| ELECTRIC CABLE LENGTH | 21' |
| HOSE LENGTH | 20' |
| TANK MATERIAL TYPE | POLYETHYLENE |
| DRY WEIGHT (LBS) | 95 |
| MANUFACTURED IN |  |



100 GALLON

| | |
|-----------------------|---|
| PRODUCT CODE | RDU100S09S |
| DIMENSIONS (LxWxH) | 47" x 34" x 34" |
| COMPATIBLE WITH | DEF |
| FILL POINT | 3/4" |
| PUMP | VANE |
| GUN | AUTO SHUT-OFF |
| FLOW RATE (GPM) | 8 |
| ELECTRIC CABLE LENGTH | 21' |
| HOSE LENGTH | 20' |
| TANK MATERIAL TYPE | POLYETHYLENE |
| DRY WEIGHT (LBS) | 105 |
| MANUFACTURED IN |  |



STOP FOR NO ONE: OUTLAST THE OTHER GUYS

When you're in the thick of your workload, the last thing you want to do is leave to refuel. With a finite amount of daylight working against you, stopping isn't an option.

The all-in-one Diesel Fuel Boss® refueling unit keeps you in the action long after everyone else has gone home. With a durable design built to handle even the toughest conditions, this diesel refueling unit is the ultimate solution for those who

want to do more. Equipped with a pump, hose, and gun, our pre-built design is ready to work right out of the box. And its built-in handles make it easy to lift out of your truck bed when you don't need it, freeing valuable bed space.



INFORMATION

WARRANTY

You can depend on your Enduraplas® equipment to work as hard as you do, and for Enduraplas® to stand behind its equipment. We now offer an industry-leading warranty because we can. Visit www.enduraplas.com/warranty for more information.

| | Standard Warranty | Extended Warranty |
|---------------------|-------------------|-------------------|
| Tanks | 5 Years | *10 Years |
| Booms & Frames | 1 Year | - |
| Parts & Accessories | **1 Year | - |

*Double your tank warranty by completing your warranty registration. Please contact your dealer for complete terms & conditions.

**Unless expressly stated that they have an extended original manufacturer warranty.

THE BRAND

The name Enduraplas® originated in 2003. Since then, the brand has spread quickly throughout USA and Canada to a point where it is a common name heard in the agriculture industry. Products with the Enduraplas® brand are recognized as high quality and premium in the markets we serve.

The following are registered (®) or unregistered (™) trademarks of Enduraplas® LLC: Enduraplas®, Engineered for Endurance®, STRONG-X™, RIBBED-WALL™, THICK-WALL™, ANCHOR-POINT™, SINGLE-PIECE™, AUTO-DRAIN™, LIFTING-LUGS™, PIN-MOUNT™, ANTI-SPLASH™, Land Champ®, Fuel Boss®, Field Boss®, Spot Chief®, Foam Ranger™, Fire Ranger™.

LEGAL NOTICE

Enduraplas® reserves the right to change specifications, design and price of the products described in this literature without notice. Images used in this literature are pictured for display purposes only. Warranty of all products is only applicable when the product is used in accord with the operator's manual. Improper use of any equipment or accessory may cause serious or fatal injury. Read, understand and follow carefully the operator's manual before using these products.

FREIGHT

Contact your local dealer to learn the exact freight charges in your area. To find your closest dealer, visit www.enduraplas.com/find-dealer.

Customer Service
cs@enduraplas.com
 1 (877) 877-4370



IMPROVING FAMILY FARM OPERATIONS™