

# WATER STORAGE TANK

View all sizes & prices on [Enduraplas.com](http://Enduraplas.com)



DESIGNED BETTER. BUILT STRONGER. LASTS LONGER.



## FLAT-SPOT™ DORMER

This tank is built with extra heavy-duty spots for plumbing extra tank fittings.

## RIBBED-WALL™ STRUCTURE

The ribs act like belts around the tank keeping it in shape. This reduces bulging.

## COMPOUND-COLOR™ INGREDIENTS

The tank color is mixed with high density polyethylene using a high-pressure extrusion process. This provides the optimum color distribution to allow even lighter colors to stop light penetration. This process reduces the amount of color pigment making the poly stronger.

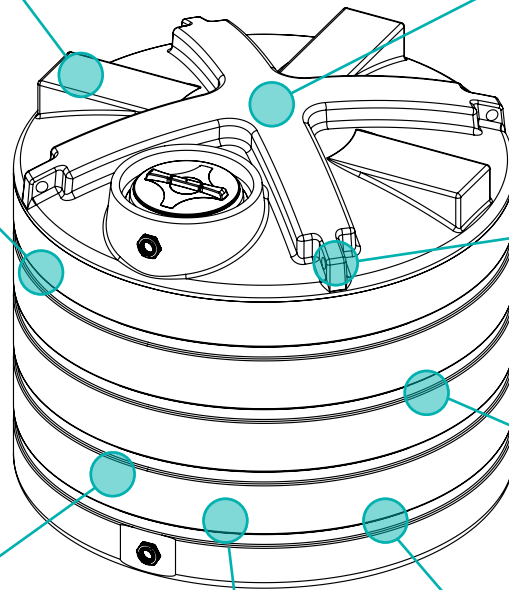

## UV-PROTECT™ EXTERIOR

This UV resistant material stops high rated sun-rays breaking down the tank side-walls.

## STRONG-X™ ROOF DESIGN

The beefed-up roof structure with molded-in truss-like supports eliminates collapsing in the heat of the day.

## ANCHOR-POINT™ LUGS

Four hefty built-in lifting and tie-down points at each corner make it easy to handle.

## LIGHT-BLOCK™ TECHNOLOGY

Algae needs light to grow. This algae-resistant material keeps the sunlight out and the water pure.

## DRINK-SAFE™ MATERIAL

The resin used to build the tank is FDA approved keeping the water safe to drink.

\*Double your 5 yr tank warranty when you register this product. \*All Enduraplas poly tanks are manufactured in the United States of America.



ENGINEERED FOR ENDURANCE®

[www.enduraplas.com](http://www.enduraplas.com)  
[info@enduraplas.com](mailto:info@enduraplas.com)  
1 (877) 877-4370